

NOTES:

1.Specification:

- 1>.Operation force: 1000gf Max.
- 2>.Operation Temperature: -30℃ to +85℃.
- 3>.Storage Temperature: -40℃ to +85℃.
- 4>.Mechanical Life: 3000 cycles operations.
- 5>.Resistance to Soldering: 260±5℃ for 3-5 Seconds.

2.PLATING:

- 1>.GOLD flash 1u”(min) SOLDERTAIL,
3u” GOLD PLATING ON THE CONTACT AREA.

3.ELECTRICAL:

- 1>.Non-switch Rating:100mA at 50V DC.
- 2>.Switching Rating: 25mA at 24V DC.
- 3>.Contact Resistance: Inital 50mΩ Max.
Contact Resistance: After life 100mΩ Max.
- 4>.Insulation Resistance:100MΩ Min at 100VDC.
- 5>.Dielectric Strength: 300V AC for 60seconds.
- 6>.Switch Capacitance: 5PF Max at 1MHZ.

4.PART NUMBER DESCRIPTION:

DSIC X I D G E I

- (包装方式:T=Tub R=Reel)
- (电镀层:E=接触位3u”/焊接位1u”)
- (电镀层:G=端子内外电镀全金)
- (端脚型:S=贴片 / D=插件 / J型)
- (L=高柄 / S=低柄 / T=低柄贴胶)
- (开关位数: 2位-----12位)

5.PACKING: 100pcs/Tube,5000pcs/Box.

MANUFACTURE DWG		 东莞市讯普电子科技有限公司 DongGuan XunPu Electronics Co.,Ltd	
UNLESS OTHERWISE SPECIFIED TOLERANCES		TITLE:PRODUCT Family DSIC Series Pitch 2.54mm	
DECIMALS:	ANGLES:	PAR	DSIC-2-TD-GET
>0±0.05	>0°±0.5°	DWN	
>1±0.10	>5°±1.0°	CHKD	
>10±0.30		APVD	
CUSTOMER COPY		SCALE:1:1	UNIT:MM
		SIZE:A4	SHEET:1F1
			REV:A

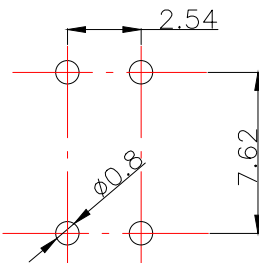
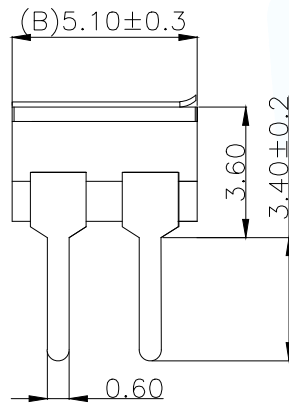
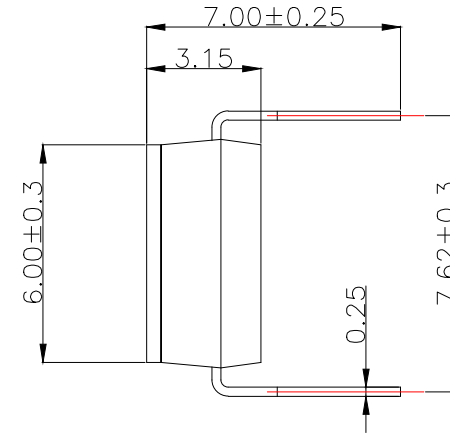
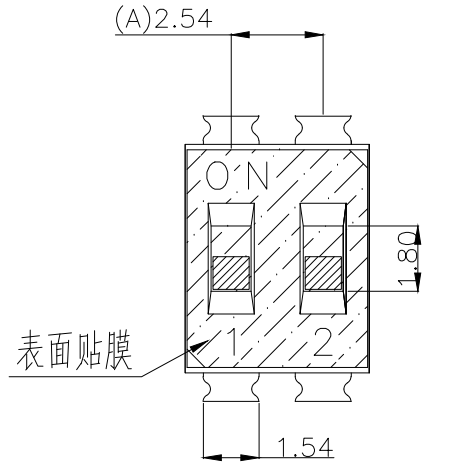

[P.C.B.LAYOUT]

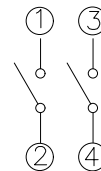

[Schematic]