

3D View

NOTES:

- 1: MATERIAL  
1-1: SUS-304 THICKNE=0.10MM
- 2: SPECIFICATIONS  
2-1: RATED CURRENT: 1.0A  
2-2: VOLTAGE RATING: 1.5V  
2-3: CONTACT RESISTANCE: 80mΩ/MAX  
2-4: WELDING THRUST: ≥3KG  
2-5: OPERATING TEMPERATURE: -40°C~+85°C
- 3: DURABILITY: 1500 CYCLES
- 4: SALT SPRAY TIME: 24H
- 5: ELECTROPLATE: THE NICKEL-PLATED SUBSTRATE IS 50u" MIN
- 6: REQUIREMENTS  
6-1: TERMINAL TO EAT FULL TIN, NOT PEELING, WELDING OBVIOUS COLOR AND OTHER ADVERSE  
6-2: ROHS, REACH, HF HALOGER ADVERSE OF DOMESTIC AND INTERNATIONAL ENVIRONMENTAL REQUIREMENTS

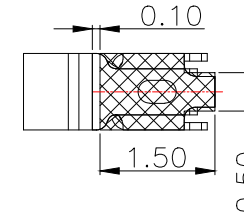
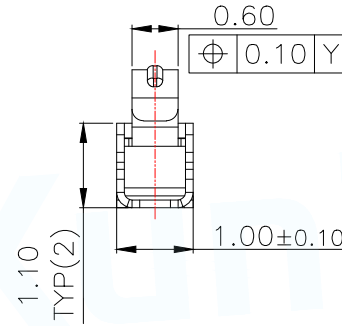
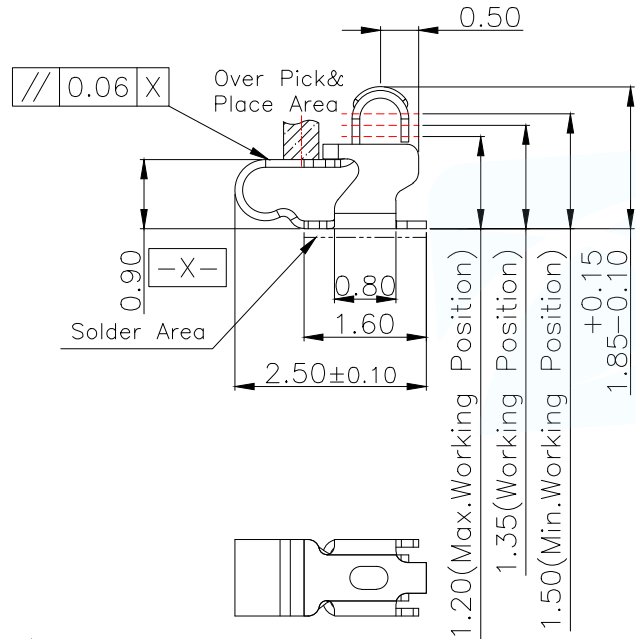

RECOMMENDED PCB LAYOUT  
TOLERANCE: ±0.05MM  
(FOR REFERENCE ONLY)

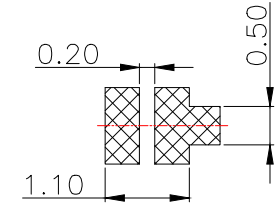

METAL MASK T=0.08  
TOLERANCE: ±0.05MM  
(FOR REFERENCE ONLY)

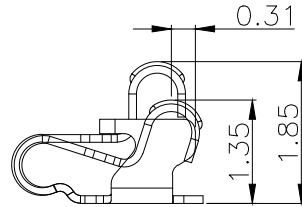
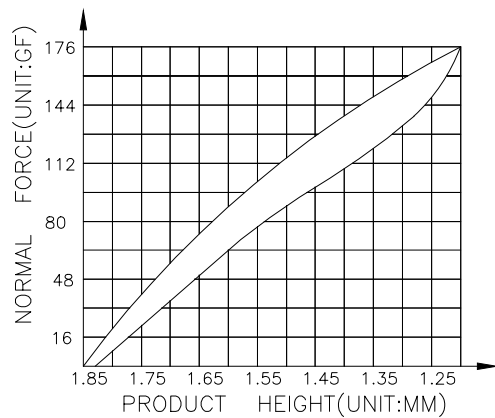

(For Reference Only)  
Stated At Compression

MANUFACTURE DWG		东莞市讯普电子科技有限公司 DongGuan XunPu Electronics Co., Ltd	
UNLESS OTHERWISE SPECIFIED TOLERANCES			TITLE: 天线弹片 L2.50*W1.00*H1.85
DECIMALS:	ANGLES:		PAR ASP-D1802-A01
X. ±0.30	X. ° ±0.20		DWN
.X ±0.20	.X ° ±0.10		CHKD
.XX ±0.15	.XX ° ±0.5	APVD	SCALE N:A UNIT:MM
CUSTOMER COPY		SIZE:A4	SHEET:1F1 REV:A

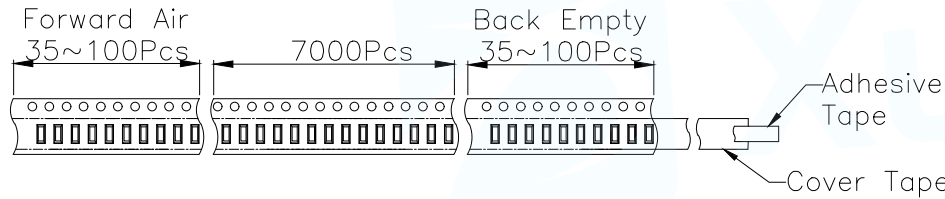
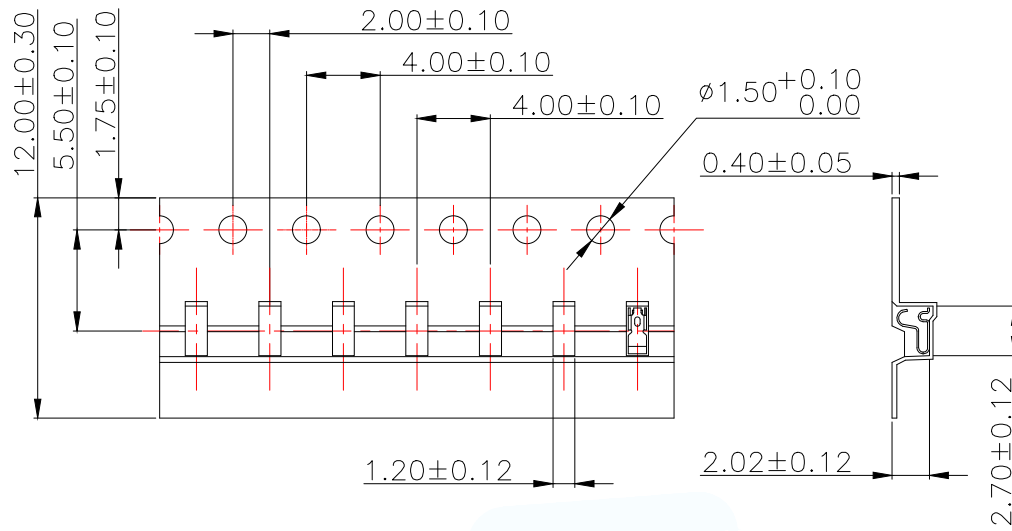

Customer To Use Direction

Pull Out Direction  
(出料方向)

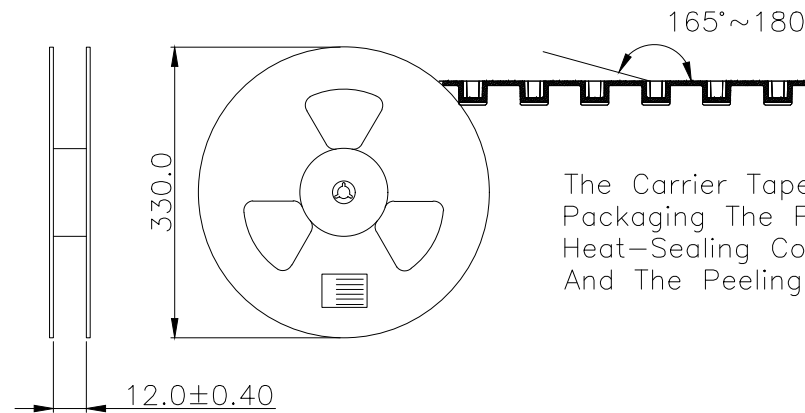

The Carrier Tape Is Heat-Sealed Packaging The Peeling Angle Of The Heat-Sealing Cover Tape Is 165°~180° And The Peeling Force Is 30~120g.

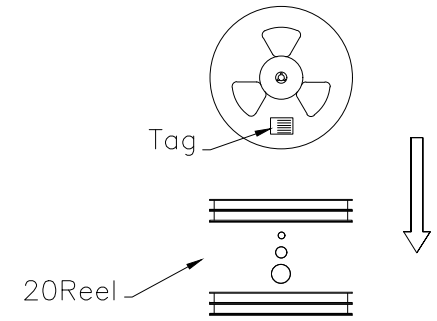

Carton Size  
290\*330\*4 K3K

Carton Size  
345\*345\*360 K=K

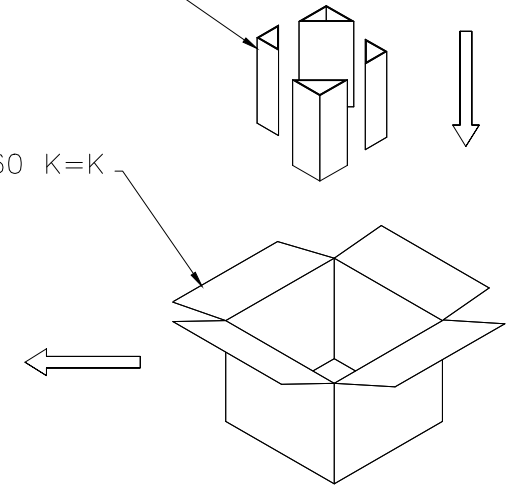
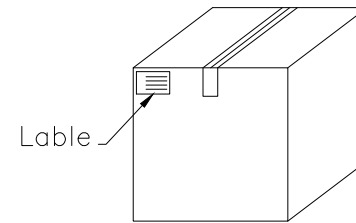

MANUFACTURE DWG		东莞市讯普电子科技有限公司 DongGuan XunPu Electronics Co.,Ltd	
UNLESS OTHERWISE SPECIFIED TOLERANCES			TITLE: 天线弹片 L2.50*W1.00*H1.85
DECIMALS:	ANGLES:		PAR ASP-D1802-A01
X. ±0.30	X. ° ±0.20	DWN	
.X ±0.20	.X ° ±0.10	CHKD	
.XX ±0.15	.XX ° ±0.5	APVD	
CUSTOMER COPY		SCALE N:A	UNIT:MM
		SIZE:A4	SHEET:1F1
			REV:A