

NOTE:

- MATERIAL SPECIFICATION:
 - HOUSING:HIGH TEMPERATURE RESISTANT PLASTIC,UL94 V-0.
 - CONTACTS:COPPER ALLOY
 - MID PLATE: STAINLESS STEEL
 - INSIDE SHELL:STAINLESS STEEL
 - OUTSIDE SHELL:STAINLESS STEEL
- PLATING SPECIFICATION:
 - CONTACTS:
 - Ni 50u" MIN. UNDER PLATED OVER ALL.
 - Au PLATED ON THE FUNCTIONAL AREA OF CONTACT. (GOLD PLATING THICKNESS FOLLOW THE P/N)
 - GOLD FLASH PLATING ON SOLDER AREA
 - INSIDE SHELL OR OUTSIDE SHELL:
 - Ni 30u" MIN. UNDER PLATED OVER ALL.
- MECHANICAL PERFORMANCE,
 - INSERTION FORCE: 0.5~2.0kgf.
 - REMOVAL FORCE: 0.8kgf~2.0kgf.
 - DURABILITY: 10000 CYCLES.
- ELECTRICAL PERFORMANCE,
 - CURRENT RATING:5A
VOLTAGE RATING:20V
 - INSULATION RESISTANCE: 100M Ω MIN
 - DIELECTRIC WITHSTAND VOLTAGE,AC 100V FOR 1 MINUTE.
 - LOW CONTACT RESISTANCE: INITIAL 40M Ω
AFTER 50M Ω
- ENVIRONMENTAL PERFORMANCE:
 - OPERATING TEMPERATURE: -30°C~+80°C.
- IR REFLOW:
 - THE PEAK TEMPERATURE ON THE BOARD SHALL BE MAINTAINED FOR 10 SECONDS AT 260°C.

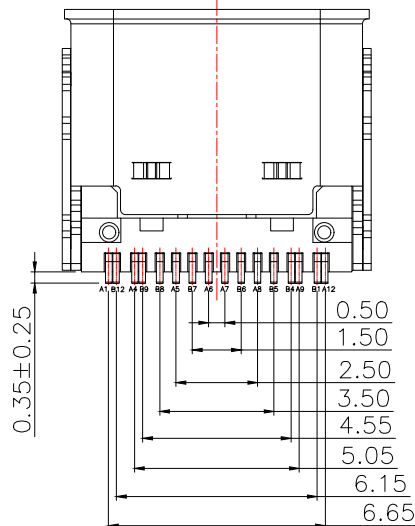

NO.	DESCRIPTION	MATERIAL	REMARKS	QUANTITY
5	OUTER SHELL	SUS304 T=0.25MM	Ni 40u"MIN	1PCS
4	INNER SHELL	SUS304 T=0.30MM	Ni 40u"MIN	1PCS
3	SHIELDING PLATE	SUS301 T=0.15MM	N/A	1PCS
2	CONTACT	C2680 T=0.15MM	Mating area 1u" Au Solder Tails:G/F Underplate: 80u"Min Ni overall	2SET
1	INSERT MOLDING	LCP UL94V-0	BLACK	1PCS

MANUFACTURE DWG			东莞市讯普电子科技有限公司 DongGuan XunPu Electronics Co.,Ltd	
UNLESS OTHERWISE SPECIFIED TOLERANCES				TITLE:USB TYPE C 16PIN, 板上垫高2.50mm(CH=4.05)
DECIMALS:	ANGLES:	PAR		TYPE-C-608-WSCL80
.X:±0.35	X.:±1°	DWN		
.XX:±0.25		CHKD		
.XXX:±0.15		APVD		
		SCALE:1:1	UNIT:MM	
		CUSTOMER COPY	SIZE:A4	SHEET:1F1
				REV:A

USB TYPE-C PIN ASSIGNMENTS

PIN NUMBER	SIGNAL NAME	PIN NUMBER	SIGNAL NAME
A1	GND	B12	GND
A4	VBUS	B9	VBUS
A5	CC1	B8	SBU2
A6	Dp1	B7	Dn2
A7	Dn1	B6	Dp2
A8	SBU1	B5	CC2
A9	VBUS	B4	VBUS
A12	GND	B1	GND

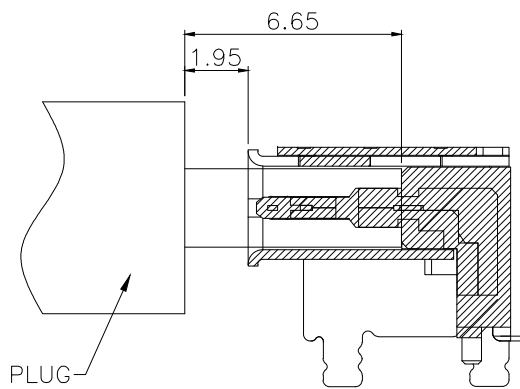

AFTER MATING
SCALE 1:1

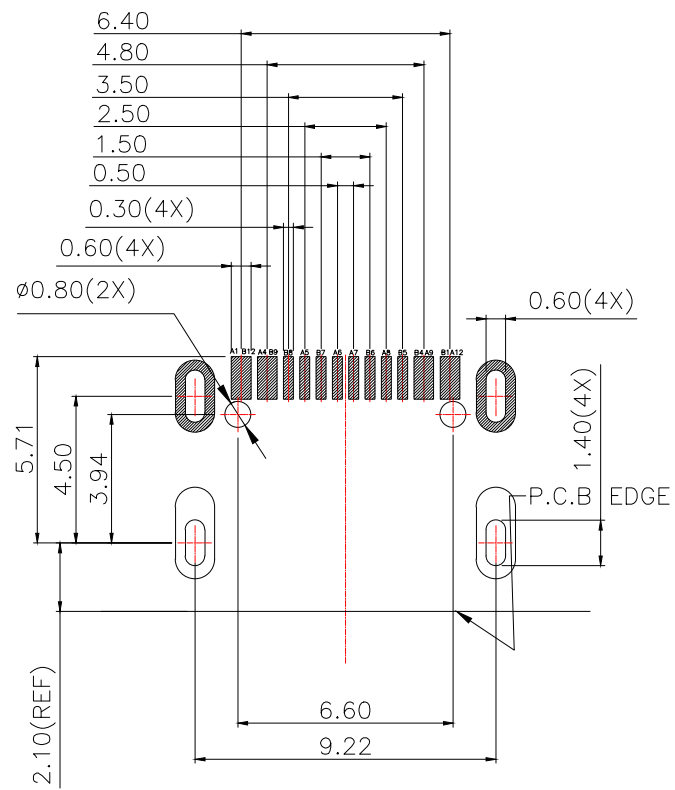

RECOMMENDED PCB LAYOUT
GENERAL TOLERANCE ± 0.05

MANUFACTURE DWG		 东莞市讯普电子科技有限公司 DongGuan XunPu Electronics Co.,Ltd	
UNLESS OTHERWISE SPECIFIED TOLERANCES			TITLE:USB TYPE C 16PIN, 板上垫高2.50mm(CH=4.05)
DECIMALS:	ANGLES:		PAR TYPE-C-608-WSCL80
.X:±0.35	X.?:±1°		DWN
.XX:±0.25			CHKD
.XXX:±0.15		APVD	SCALE 1:1 UNIT:MM
CUSTOMER COPY		SIZE:A4	SHEET:1F1 REV:A

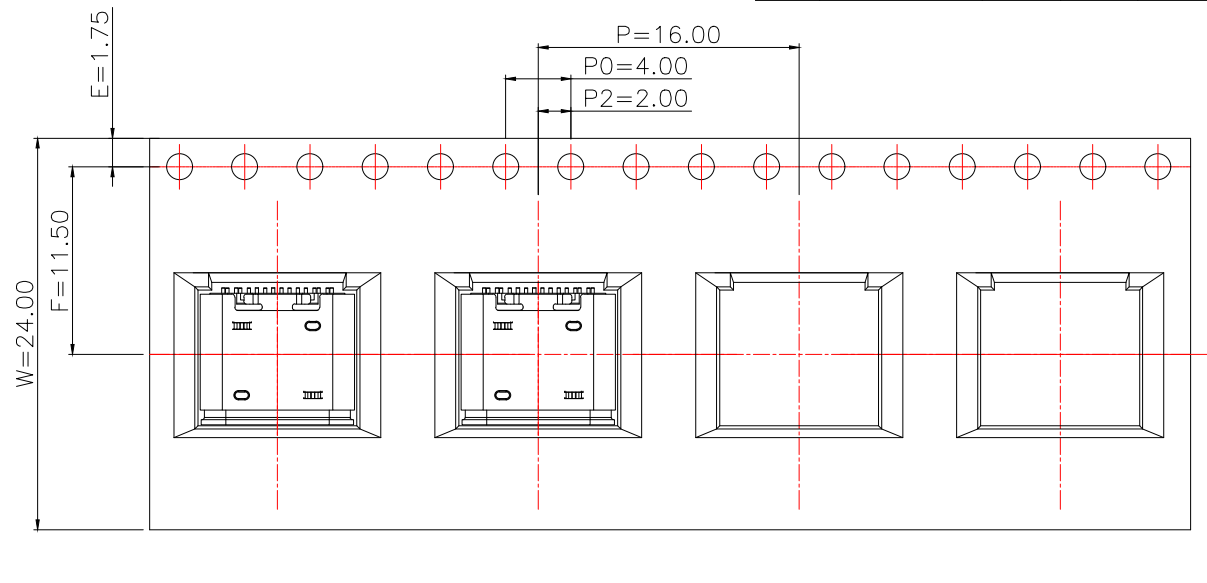
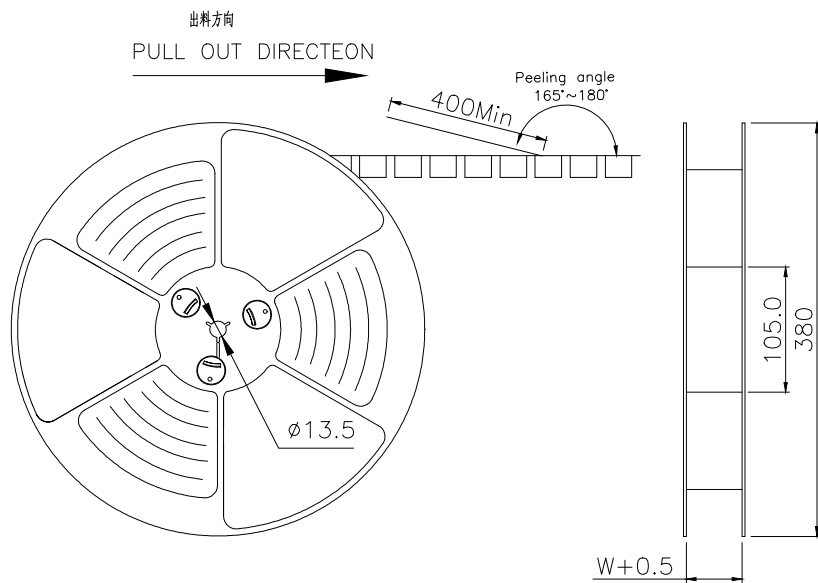

NOTES

- 带子引导长度
LEAD TAPE LENGTH
出料方向 PULL OUT DIRECTEON
出料方向 PULL OUT DIRECTEON
600PCS产品
后空5PCS
前空5PCS
- 上带剥离力为:0.1~1.3N(10.2gf~130gf)
PEELING OFF FORCE OF TOP TAPE:0.1~1.3N(10.2gf~130gf)
出货,运输过程中一定注意:
THIS REQUIREMENT SHOULD BE APPLIED AT SHIPMENT:
卷带在运输过程中不能散开
PEELING OFF SHOULD NOT BE ALLOWED DURING TRANSPORTATION

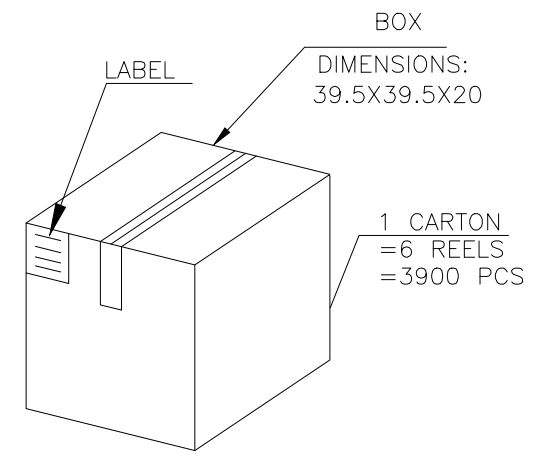
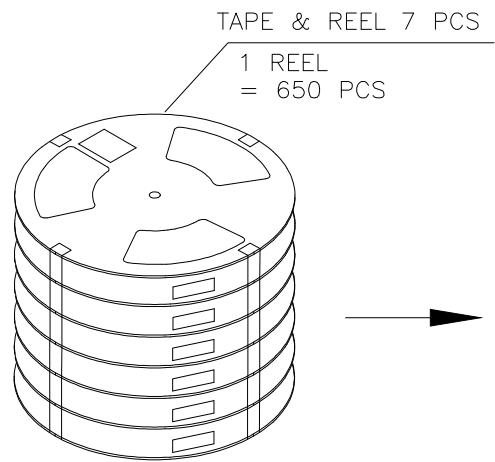

包装明细表 (The detail of the packing) Carton						
产品料号 (Product No.)	包装容量 (Packing Capacity)			重量 Weight (Kg)		
	pcs/box	boxs/Carton	Pcs/Box	N.W./Pcs	N.W./Box	G.W./Box
	650	6	3900	---	---	---

MANUFACTURE DWG				
UNLESS OTHERWISE SPECIFIED TOLERANCES			TITLE:USB TYPE C 16PIN, 板上垫高2.50mm(CH=4.05)	
DECIMALS:	ANGLES:		PAR	TYPE-C-608-WSCL80
.X:±0.35	X.:±1°		DWN	
.XX:±0.25		CHKD		
.XXX:±0.15		APVD		
		SCALE 1:1	UNIT:MM	
		CUSTOMER COPY	SIZE:A4	
			SHEET:1F1	REV:A