

Specification:

- Electrical Characteristics:
Contact Current Rating:0.5 Amperes.
Dielectric Withstanding Voltage:AC500V r.m.s.
Insulation Resistance:1000 MΩ Minimum.
Contact Resistance:40 mΩ Maximum.
- Environmental:
Operating Temperature:-25°C~+90°C.
- Environmental:
Mating Cycles:5,000 Insertions.
- Mechanical Characteristics:
Card Push Insertion/Out Force:0.2~1.40kgf.
Contact Separation Force:0.20kgf Minimum.
- Material:
Insulator:HI-Temp Plastic UL 94V-0 Rated.
Contact:Copper Alloy(t=0.15mm).
Shell:Stainless Steel(t=0.15mm).
Spring:SWP.

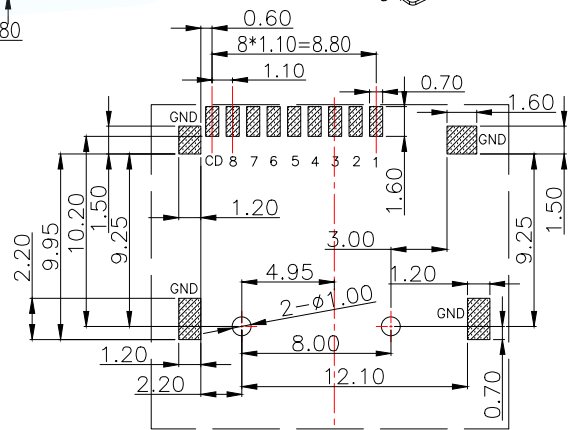
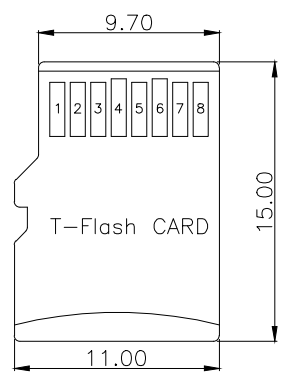
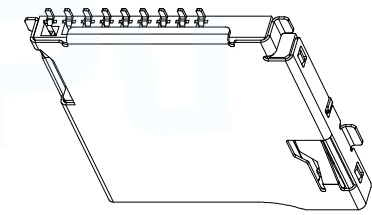
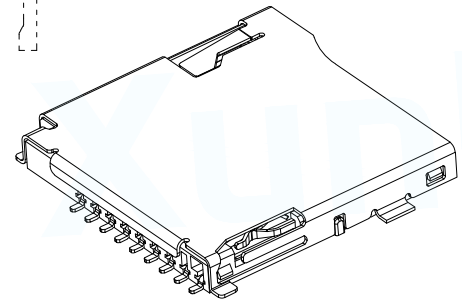
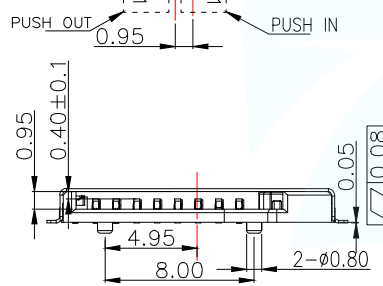

▨ PAD AREA
■ KEEP OUT AREA

RECOMMENDED PCB LAYOUT
GENERAL TOLERANCE ±0.05

Circuit Diagram for Detect Switch

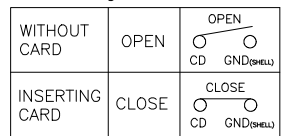

PIN NO.	NAME	YTYPE	DESCRIPTION
1	DAT2	I/O/PP	DATE LINE(BIT2)
2	CD/DAT3	I/O/PP	CARD DETECT DATE LIN(BIT3)
3	CMD	PP	COMMAND RESPONSE
4	VDD	S	SUPPLY VOLTAGE
5	CLX	I	CLOCK
6	VSS	S	SUPPLY VOLTAGE GROUND
7	DAT0	I/O/PP	DATE LINE(BIT0)
8	DAT1	I/O/PP	DATE LINE(DIT1)

MANUFACTURE DWG		东莞市讯普电子科技有限公司 DongGuan XunPu Electronics Co.,Ltd	
UNLESS OTHERWISE SPECIFIED TOLERANCES			TITLE:MICRO SD CARD PUSH PUSH SMT 镀金 外焊
DECIMALS:	ANGLES:		PAR TF-115-ACP9
X.X:±0.35	X.X':±3°		DWN
X.XX:±0.25	X.XX':±2°		CHKD
X.XXX:±0.15		APVD	SCALE:1:1 UNIT:MM
CUSTOMER COPY		SIZE:A4	SHEET:1F1 REV:A

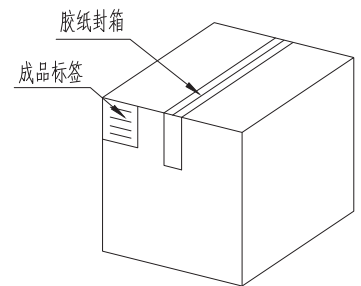
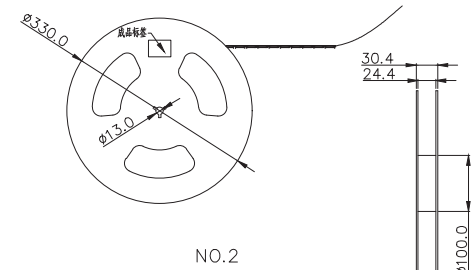
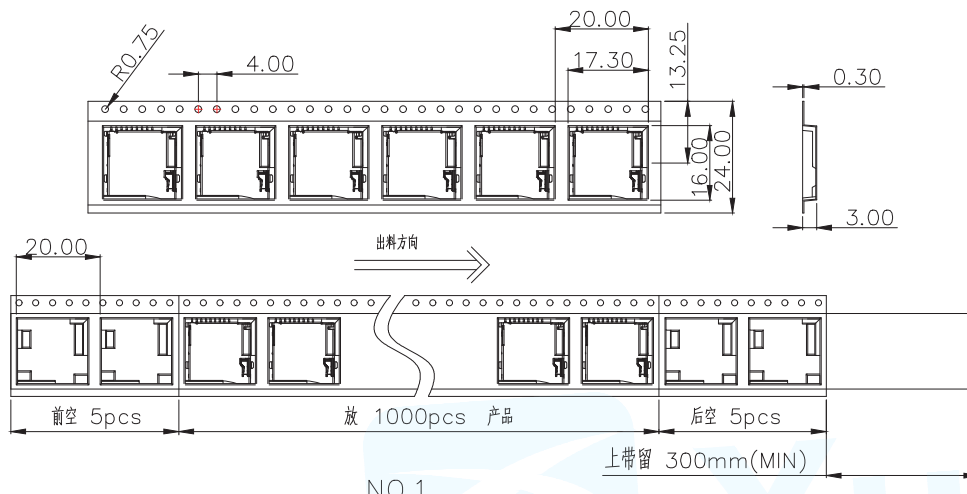

纸箱规格: 340*340*385

NO.4

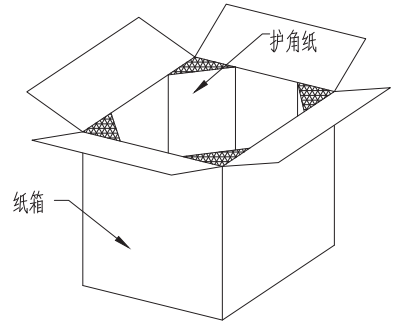
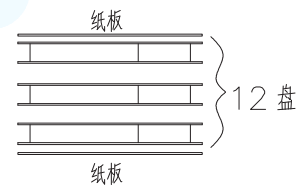

NO.3

1. 材质要求:

- 1.1 纸箱的材质为K=K;外形尺寸为34*34*38.5;
- 1.2 卷盘的材质为PS,卷盘的外形尺寸为 $\phi 330*30.4$;
- 1.3 卷带的材质为PS,卷带的外形尺寸为20200*24.00*3.0mm;

2. 包装方式:

- 2.1 将卷带放入包装机后,前空5PCS,后放产品1000PCS,再后空5PCS;上带留300MM长度。
- 2.2 将包装好的产品从包装机上取下并包装好,贴上内盘标签;
- 2.3 把累叠好的12盘放入纸箱中共计12Kset,上下放纸板,纸箱四个角塞护角纸;
- 2.4 把包装好的成品打包封箱,并在纸箱外贴上标签

MANUFACTURE DWG		东莞市讯普电子科技有限公司 DongGuan XunPu Electronics Co.,Ltd		
UNLESS OTHERWISE SPECIFIED TOLERANCES			TITLE: MICRO SD CARD PUSH PUSH SMT 镀金 外焊	
			PAR	TF-115-ACP9
DECIMALS:	ANGLES:		DWN	
X.X: ± 0.35	X.X': $\pm 3'$		CHKD	
X.XX: ± 0.25	X.XX': $\pm 2'$	APVD		
X.XXX: ± 0.15		SCALE: 1:1	UNIT: MM	
CUSTOMER COPY		SIZE: A4	SHEET: 1F1	