

"E"向视图

NOTE:

- MATERIAL SPECIFICATION:
 - HOUSING: HIGH TEMPERATURE RESISTANT PLASTIC, UL94 V-0.
 - TERMINAL: COPPER ALLOY
 - MID PLATE: STAINLESS STEEL
 - FRONT SHELL: STAINLESS STEEL
- PLATING SPECIFICATION:
 - TERMINAL:
 - Ni 50u" MIN. UNDER PLATED OVER ALL.
 - Au PLATED ON THE FUNCTIONAL AREA OF CONTACT.
 - (GOLD PLATING THICKNESS FOLLOW THE P/N)
 - PLATING SPECIFICATIONS OF THE SOLDER AREA FOLLOW THE P/N
 - FRONT SHELL:
 - PLATING SPECIFICATIONS FOLLOW THE P/N
 - MID PLATE:
 - CLEAR ONLY
- MECHANICAL PERFORMANCE,
 - INSERTION FORCE: 0.5~2.0kgf.
 - REMOVAL FORCE: 0.8kgf~2.0kgf.
 - DURABILITY: 10000 CYCLES.
- ELECTRICAL PERFORMANCE,
 - VOLTAGE RATING: 5 V DC/AC (RMS. max)
CURRENT RATING: 3 AMPS. FOR TOTAL VBUS/GND PINS;
1.25AMPS FOR CC PIN, 0.25 AMPS. FOR ALL OTHER CONTACT.
 - LLCR:
 - VBUS & GND PINS AND OTHER PINS: 40mA/PIN MAX.
 - SHIELD: 50mA/MAX.
 - LLCR MAX. CHANGE OF ALL PINS: 10mA.
 - INSULATION RESISTANCE: 100MΩ MIN
 - DIELECTRIC WITHSTAND VOLTAGE, AC 100V FOR 1 MINUTE.
- ENVIRONMENTAL PERFORMANCE:
 - OPERATING TEMPERATURE: -25°C~+85°C.
- IR REFLOW:
 - THE PEAK TEMPERATURE ON THE BOARD SHALL BE MAINTAINED FOR 10 SECONDS AT 260°C.
- WATERPROOF: IPX5

MANUFACTURE DWG		东莞市讯普电子科技有限公司 DongGuan XunPu Electronics Co., Ltd	
UNLESS OTHERWISE SPECIFIED TOLERANCES			TITLE: USB TYPE C 6pos Top-mount SMT Waterproof
			PAR TYPE-C-316-WSCX5
DECIMALS:	ANGLES:		DWN
X.X: ±0.30	X.': ±10°		CHKD
X.XX: ±0.20	.X': ±8°	APVD	SCALE 1:1
X.XXX: ±0.10	.XX': ±0.5°	CUSTOMER COPY	UNIT: MM
		SIZE: A4	UNIT: MM
		SHEET: 1F1	REV: A

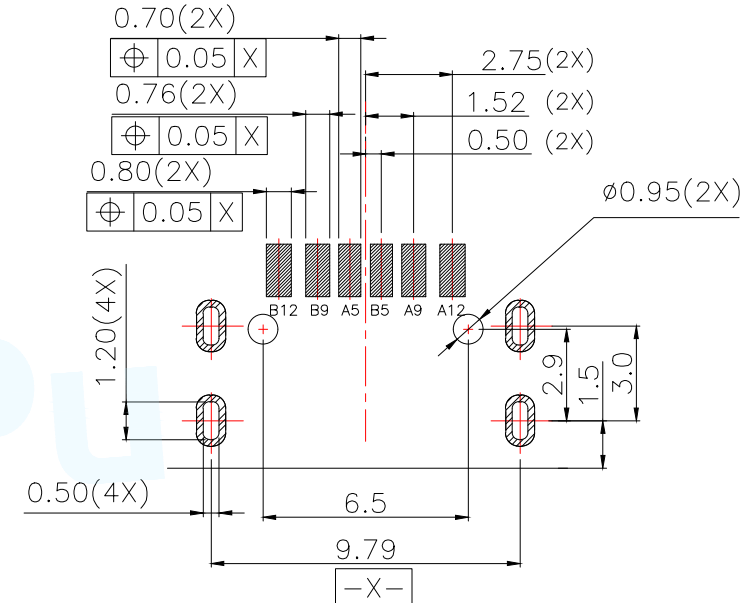
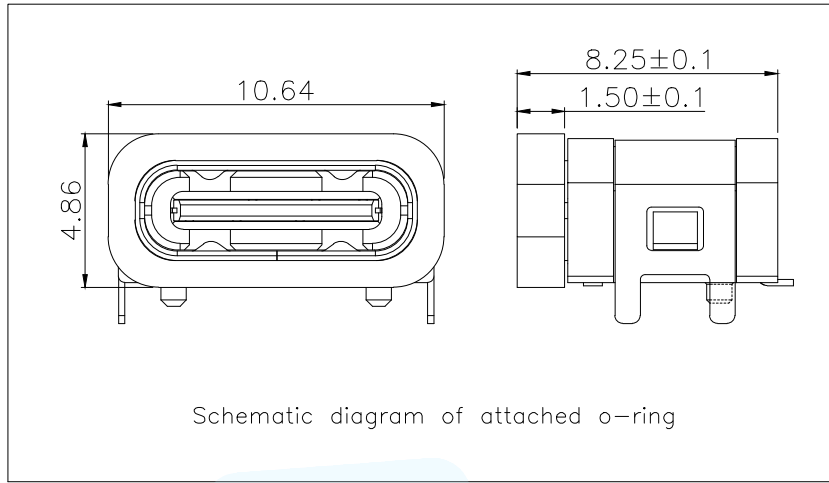

RECOMMENDED PCB LAYOUT(TOP VIEW)
THICKNESS 0.80MM;DEFAULT TOLERANCE:±0.05

USB TYPE-C PIN ASSIGNMENTS

PIN NUMBER	SIGNAL NAME	PIN NUMBER	SIGNAL NAME
A1		B12	GND
A2		B11	
A3		B10	
A4		B9	VBUS
A5	CC1	B8	
A6		B7	
A7		B6	
A8		B5	CC2
A9	VBUS	B4	
A10		B3	
A11		B2	
A12	GND	B1	

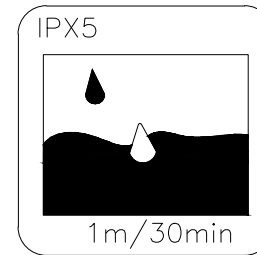

MANUFACTURE DWG			东莞市讯普电子科技有限公司 DongGuan XunPu Electronics Co.,Ltd	
UNLESS OTHERWISE SPECIFIED TOLERANCES			TITLE: USB TYPE C 6pos Top-mount SMT Waterproof PAR TYPE-C-316-WSCX5	
DECIMALS:	ANGLES:	CUSTOMER COPY	DWN	
X.X:±0.30	X.°:±10°		CHKD	
X.XX:±0.20	.X':±8'		APVD	
X.XXX:±0.10	.XX':±0.5°		SCALE:1:1	UNIT:MM
		SIZE:A4	SHEET:1F1	REV:A

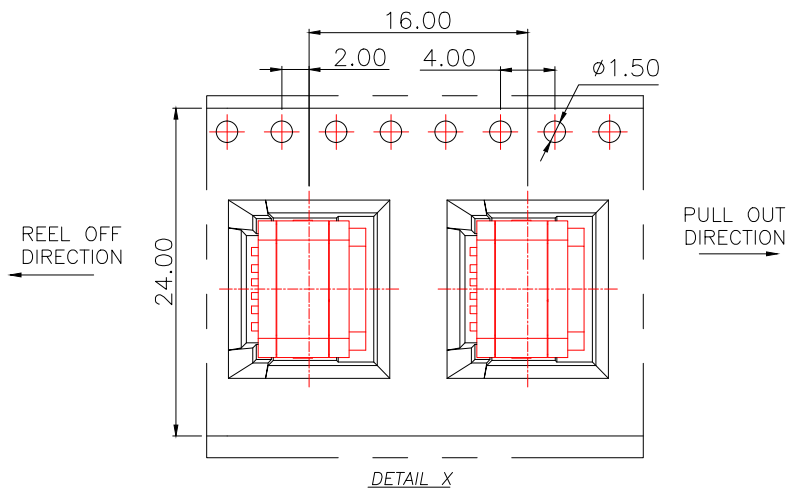
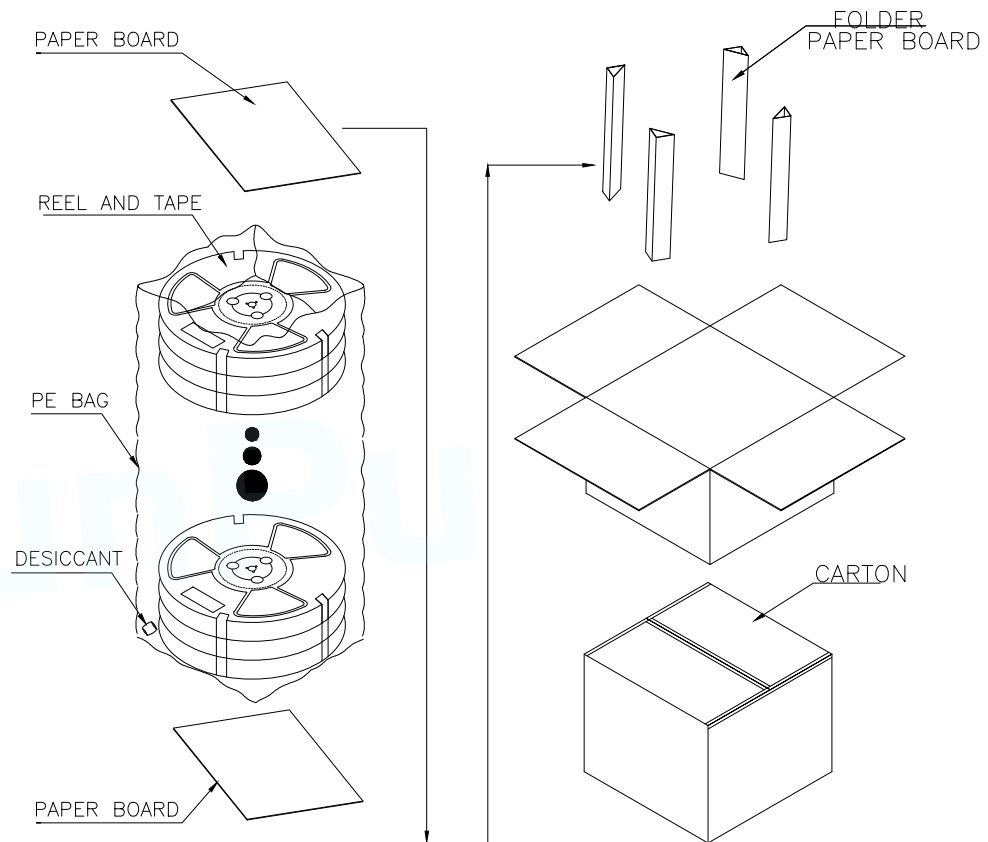
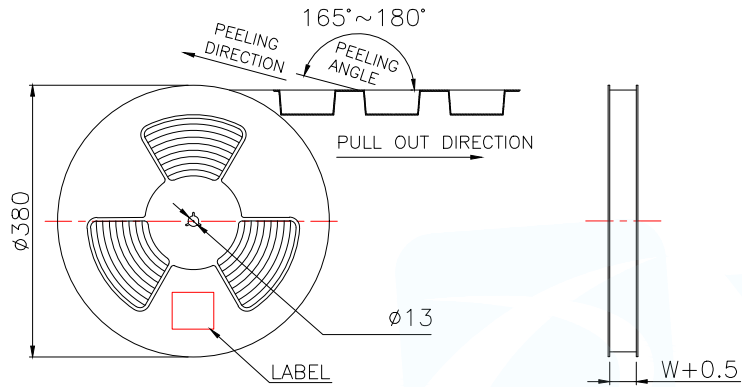
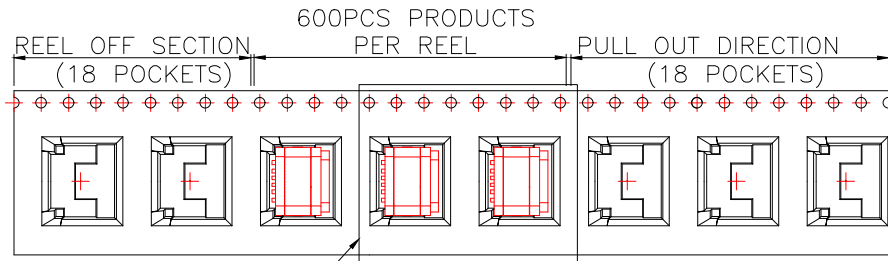

	REEL/TRAY	CARTON
CONNECTOR (PCS)	600	6000

MANUFACTURE DWG		 东莞市讯普电子科技有限公司 DongGuan XunPu Electronics Co.,Ltd	
UNLESS OTHERWISE SPECIFIED TOLERANCES			TITLE: USB TYPE C 6pos Top-mount SMT Waterproof
			PAR TYPE-C-316-WSCX5
DECIMALS:	ANGLES:		DWN
X.X:±0.30	X.°:±10°		CHKD
X.XX:±0.20	.X':±8"	APVD	
X.XXX:±0.10	.XX":±0.5°	CUSTOMER COPY	SCALE:1:1 UNIT:MM
		SIZE:A4	UNIT:MM
		SHEET:1F1	REV:A