

12	13	14	15
MAPX	MODIFICATION	DATE	DRAW

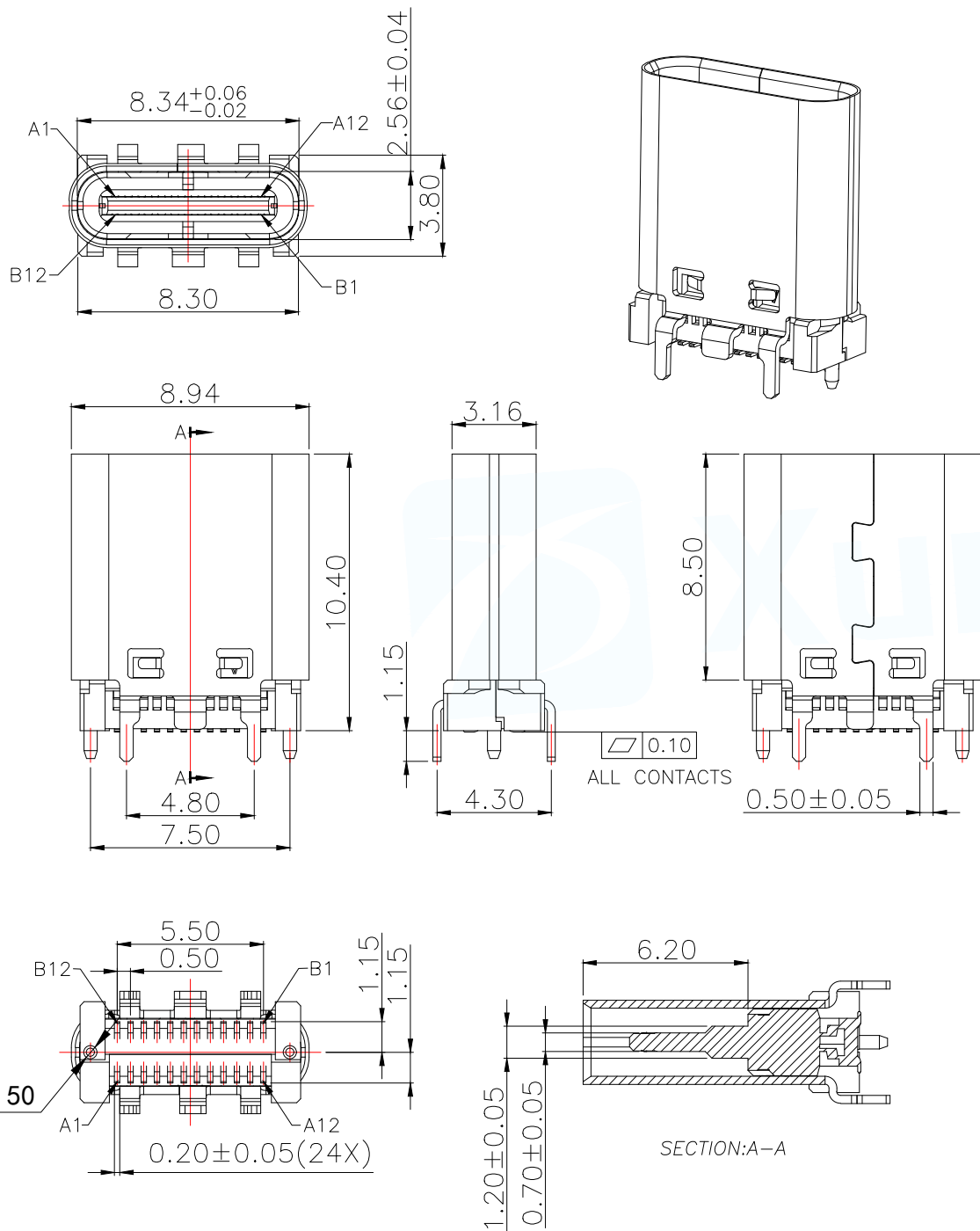

NOTE:

- MATERIAL SPECIFICATION:
 - HOUSING: HIGH TEMPERATURE RESISTANT PLASTIC, UL94 V-0
 - TERMINAL: COPPER ALLOY (C1814)
 - MID PLATE: STAINLESS STEEL (SUS301)
 - FRONT SHELL: STAINLESS STEEL (SUS304)
 - EMI PLATE: STAINLESS STEEL (SUS304)
- PLATING SPECIFICATION:
 - TERMINAL:
 - Ni 50u" MIN. UNDER PLATED OVER ALL.
 - Au PLATED ON THE FUNCTIONAL AREA OF CONTACT.
 - CONTACT FUNCTIONAL AREA PLATED : Au G/F
 - CONTACT SOLDER AREA PLATED : Au G/F
 - FRONT SHELL:
 - Ni 30u" MIN. UNDER PLATED OVER ALL.
 - MID PLATE & EMI PLATE:
 - CLEAR ONLY
- MECHANICAL PERFORMANCE,
 - INSERTION FORCE: 0.5~2.0kgf.
 - REMOVAL FORCE: 0.8kgf~2.0kgf.
 - DURABILITY: 10000 CYCLES.
- ELECTRICAL PERFORMANCE,
 - VOLTAGE RATING: 30V DC/AC (RMS. max)
CURRENT RATING: 5AMPS. FOR TOTAL VBUS/GND PINS;
1.25AMPS FOR CC PIN, 0.25 AMPS. FOR ALL OTHER CONTACT.
 - LLCR:
 - VBUS & GND PINS AND OTHER PINS: 40mA/PIN MAX.
 - SHIELD: 50mA/MAX.
 - LLCR MAX. CHANGE OF ALL PINS: 10mA.
 - INSULATION RESISTANCE: 100M Ω MIN
 - DIELECTRIC WITHSTAND VOLTAGE, AC 100V FOR 1 MINUTE.
- ENVIRONMENTAL PERFORMANCE:
 - OPERATING TEMPERATURE: -40°C~+85°C.
- IR REFLOW:
 - THE PEAK TEMPERATURE ON THE BOARD SHALL BE MAINTAINED FOR 10 SECONDS AT 260°C.

MANUFACTURE DWG		 东莞市讯普电子科技有限公司 DongGuan XunPu Electronics Co., Ltd	
UNLESS OTHERWISE SPECIFIED TOLERANCES			TITLE: Type.C 24PIN H10.4 Vertical CONN. RECPTACLE
			PAR TYPEC-501-ACP24
DECIMALS:	ANGLES:		DWN
X.X: ±0.30	X.' : ±2'		CHKD
X.XX: ±0.20	.X' : ±1'	APVD	SCALE 1:1 UNIT: MM
X.XXX: ±0.10		CUSTOMER COPY	SIZE: A4 SHEET: 1F1 REV: A

USB TYPE-C PIN ASSIGNMENTS

PIN NUMBER	SIGNAL NAME	PIN NUMBER	SIGNAL NAME
A1	GND	B12	GND
A2	SSTXp1	B11	SSRXp1
A3	SSTXn1	B10	SSRXn1
A4	VBus	B9	VBus
A5	CC1	B8	SBU2
A6	Dp1	B7	Dn2
A7	Dn1	B6	Dp2
A8	SBU1	B5	CC2
A9	VBus	B4	VBus
A10	SSRXn2	B3	SSTXn2
A11	SSRXp2	B2	SSTXp2
A12	GND	B1	GND

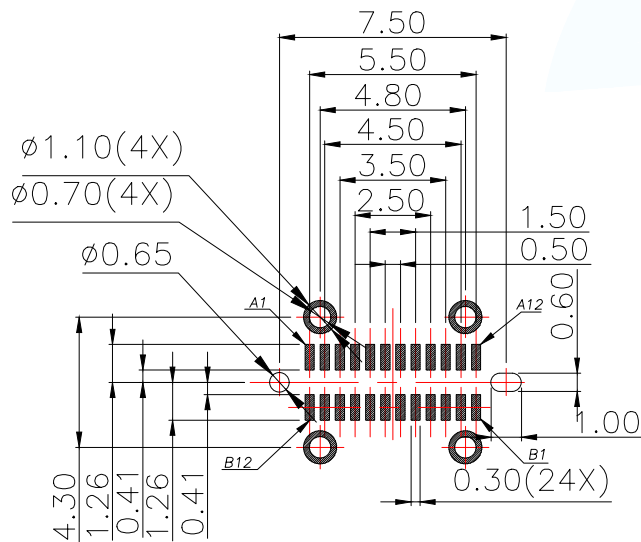
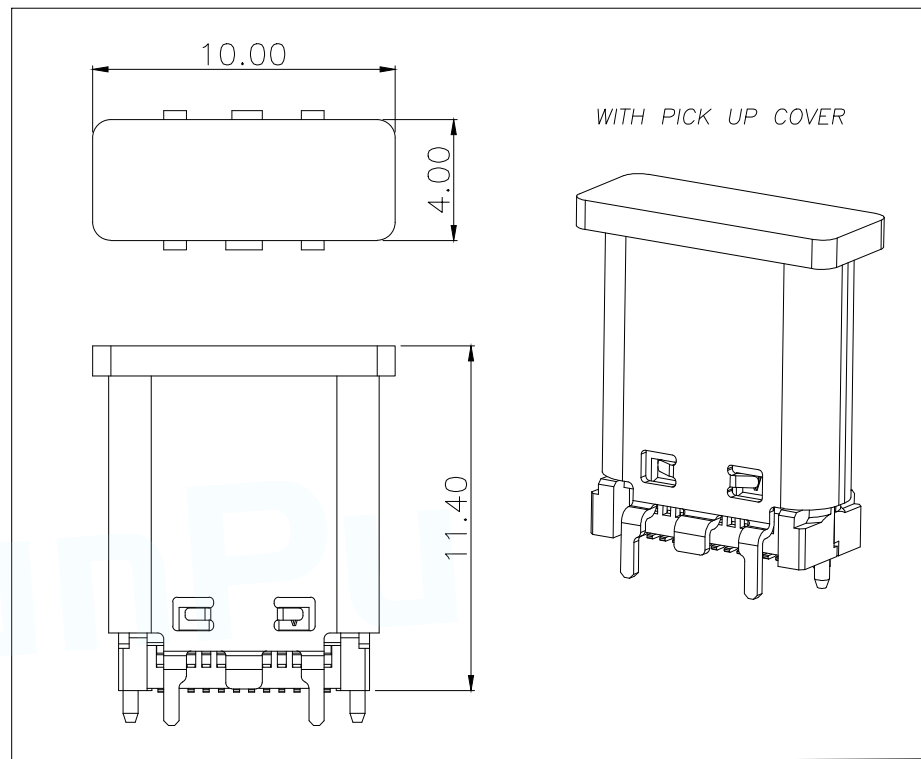

RECOMMENDED PCB LAYOUT(TOP VIEW)
THICKNESS 1.0±0.10MM;DEFAULT TOLERANCE:±0.05

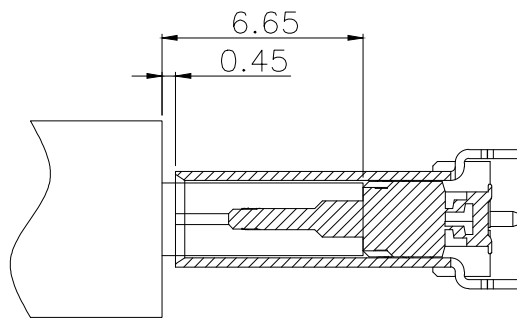

AFTER MATING

MANUFACTURE DWG		 东莞市讯普电子科技有限公司 DongGuan XunPu Electronics Co.,Ltd	
UNLESS OTHERWISE SPECIFIED TOLERANCES			TITLE: Type.C 24PIN H10.4 Vertical CONN. RECPTACLE
DECIMALS:	ANGLES:		PAR TYPEC-501-ACP24
X.X:±0.30	X.':±2'		DWN
X.XX:±0.20	.X':±1'		CHKD
X.XXX:±0.10		APVD	SCALE 1:1 UNIT:MM
CUSTOMER COPY		SIZE:A4	SHEET:1F1
			REV:A

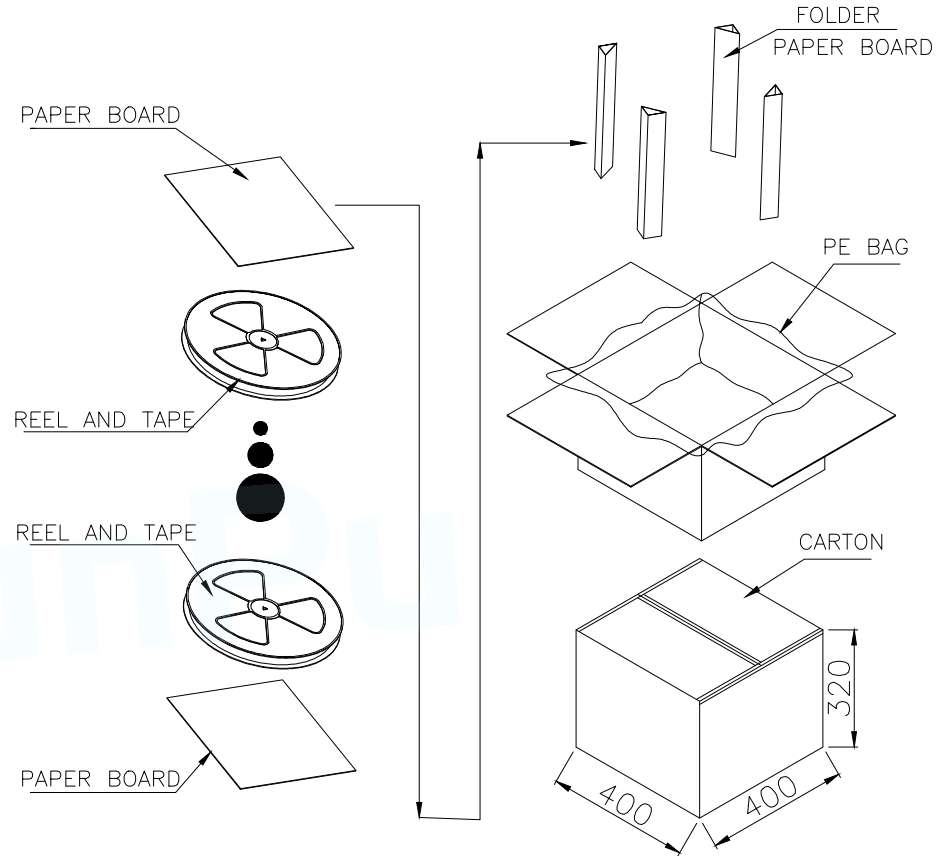
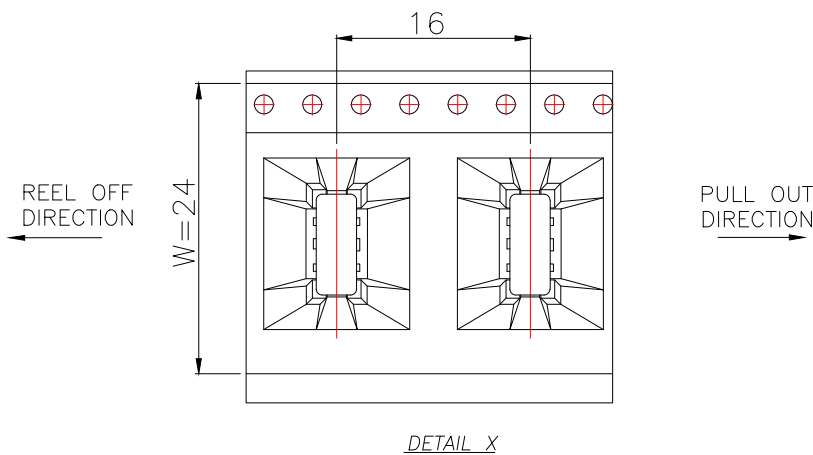
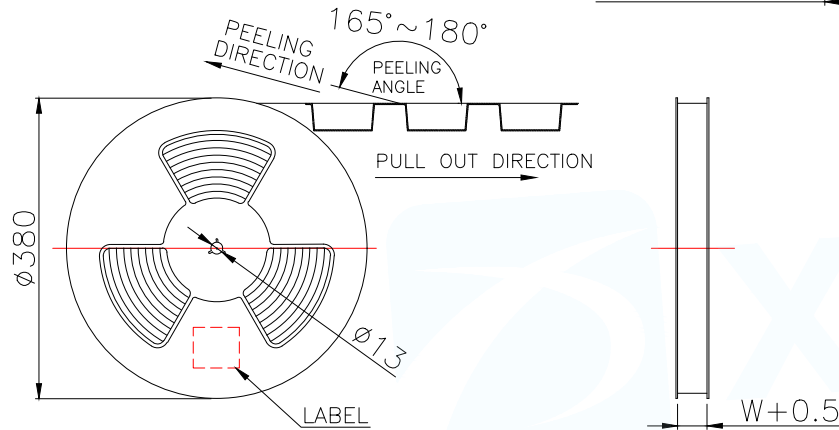
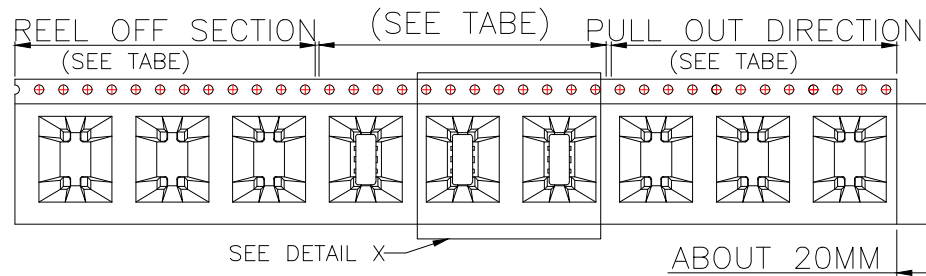

MANUFACTURE DWG		东莞市讯普电子科技有限公司 DongGuan XunPu Electronics Co.,Ltd	
UNLESS OTHERWISE SPECIFIED TOLERANCES			TITLE: Type.C 24PIN H10.4 Vertical CONN. RECPTACLE
DECIMALS:	ANGLES:		PAR TYPEC-501-ACP24
X.X:±0.30	X.':±2'		DWN
X.XX:±0.20	.X':±1'		CHKD
X.XXX:±0.10		APVD	SCALE:1:1 UNIT:MM
CUSTOMER COPY		SIZE:A4	UNIT:MM
		SHEET:1F1	REV:A