

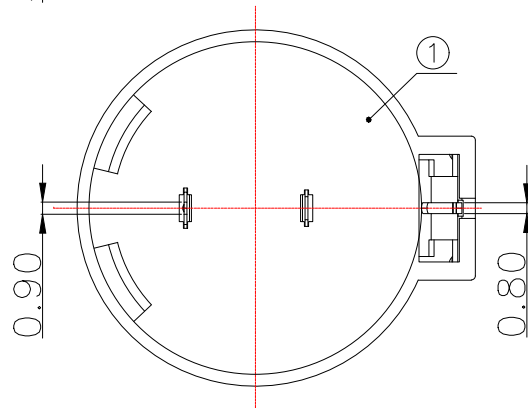

12	13	14	15
MAPX	MODIFICATION	DATE	APPROVE

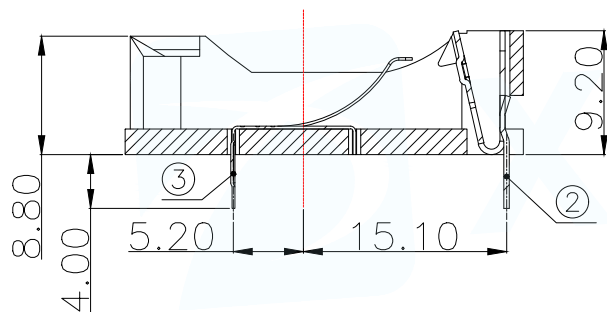
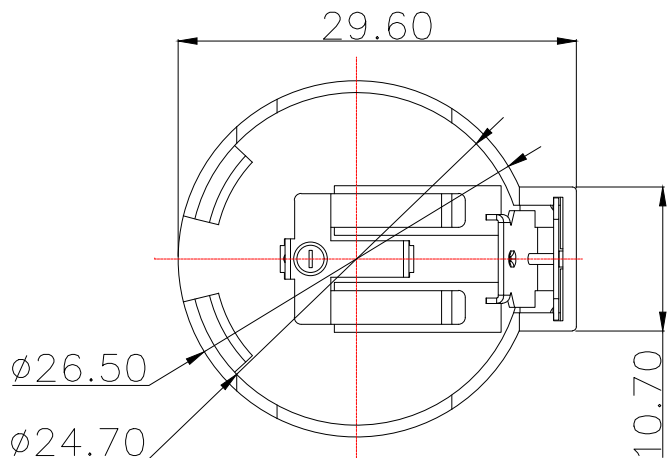

NOTE:

1.MATERIAL:

a.HOUSING:PBT

b.CONTACT:PHOSPHOR BRONZE

(SURFACE PLATING: Ni100u"-120u")

2.ELECTRIC:

a.CONTACT RESISTANCE: 100 MILLIOHMS
MAX

b.INSULATION RESISTANCE: 100 MEGA
OHMS MIN

c.DIELECTNIC VOLTAGE: 500V AC ONE
SEC LEVEL

d.OPERATING TEMPERATURE: -25°C~
+85°C

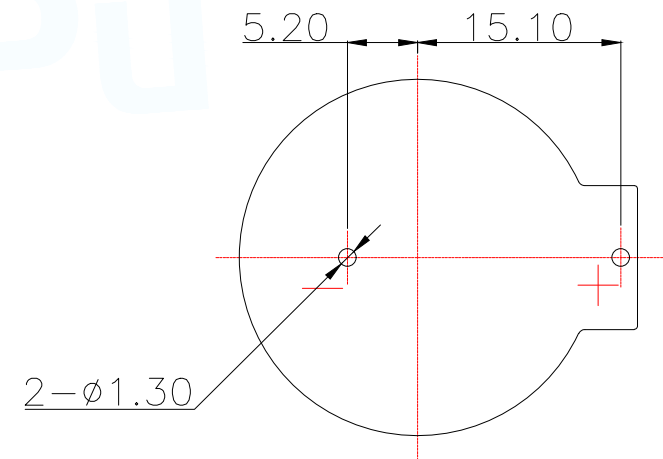

PCB Layout Diagram
Top View

3	TERMINAL(-)	1	PHOSPHOR BRONZE, T=0.15mm	Ni Plating
2	TERMINAL(+)	1	PHOSPHOR BRONZE, T=0.15mm	Ni Plating
1	HOUSING	1	PBT	BLACK
NO.	PART NAME	Q'TY	MATERIAL	PLATING & COLOR

MANUFACTURE DWG		东莞市讯普电子科技有限公司 DongGuan XunPu Electronics Co.,Ltd	
UNLESS OTHERWISE SPECIFIED TOLERANCES		TITLE: DIP	
DECIMALS: X.X±0.30			PAR BS-2401-DJ-0B
ANGLES: X.*±5'			DWN
X.XX±0.25			CHKD
X.XXX±0.15		APVD	UNIT:MM
		SCALE N:A	UNIT:MM
		SIZE:A4	SHEET:1F1
		CUSTOMER COPY	REV:A