

MAPX	MODIFICATION	DATE	DRAW	APPROVE

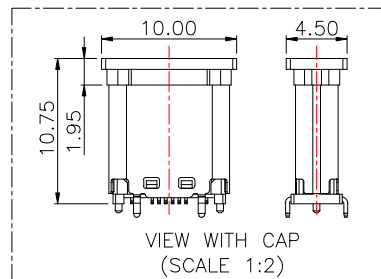
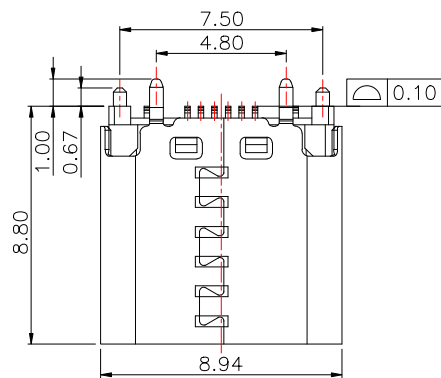

SPECIFICATION:

- MATERIAL & FINISH:SEE THE LIST;
- PLATING SPECIFICATION:
 - CONTACTS:
 - Ni 50u" MIN. UNDER PLATED OVER ALL.
 - Au PLATED ON THE MATING AREA OF CONTACT.
 - Au PLATED ON THE SOLDER AREA.
 - SHELL:Ni 30u" MIN. UNDER PLATED OVER ALL.
 - MID PLATE:CLEAR ONLY
- MECHANICAL:
 - MATING FORCE:0.5~2.0kgf;
 - UNMATING FORCE:0.8~2.0kgf.
 - DURABILITY:10000 CYCLES;
- ELECTRICAL:
 - CURRENT RATING:5A Max;
 - VOLTAGE RATING:20V Max;
 - DIELECTRIC WITHSTANDING VOLTAGE:100VAc;
 - CONTACT RESISTANCE:40mΩ Ohms Max.;
 - INSULATION RESISTANCE:100M Ohms Min.;
- ENVIRONMENTAL:
 - OPERATING TEMPERATURE:-40°C~+85°C;
 - WETTING TEMPERATURE:265±5°C,5±0.5s
 - Salt Spray Test:48H Min

PIN	SIGNAL	PIN	SIGNAL
A12	GND	B1	GND
A11	---	B2	---
A10	---	B3	---
A9	VBUS	B4	VBUS
A8	SBU1	B5	CC2
A7	D-	B6	D+
A6	D+	B7	D-
A5	CC1	B8	SBU2
A4	VBUS	B9	VBUS
A3	---	B10	---
A2	---	B11	---
A1	GND	B12	GND

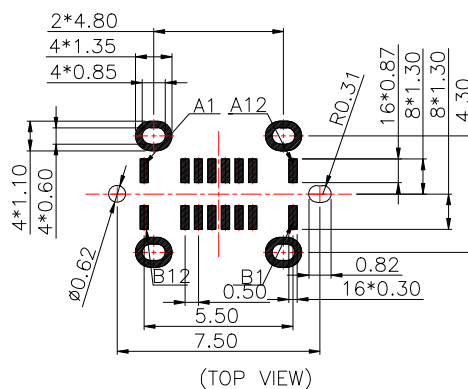
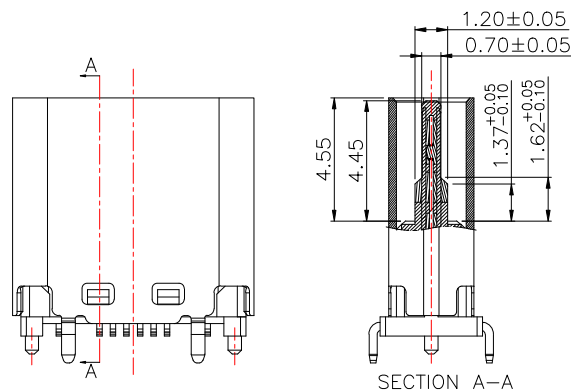
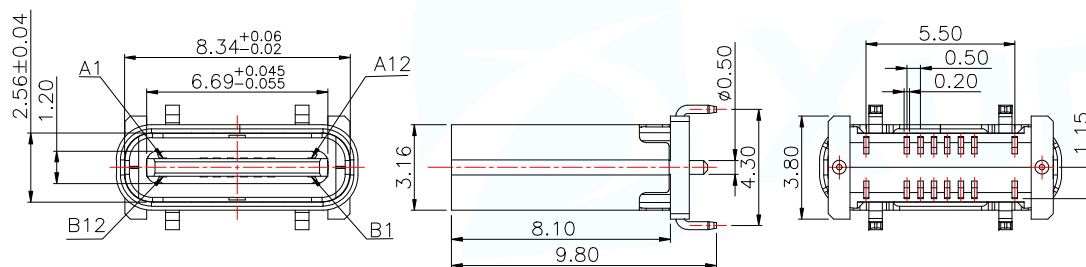

RECOMMENDED P.C.B. LAYOUT (T:0.8mm)
TOLERANCE UNSPECIFIED ±0.05mm

NO.	PN.	DESCRIPTION
1	TYPEC-501Y-BCP24H88	不锈钢外壳,黑色胶芯,C7025端子接触区镀金1u",焊脚镀金1u"
2	TYPEC-501Y-ACP24H88	不锈钢外壳,黑色胶芯,C7025端子接触区镀金3u",焊脚镀金1u"

NO.	PART NAME	Q'TY	MATERIAL	FINISH
5	CAP	1	High temperature plastic	UL94 V-0,Black
4	Shell	1	Stainless Steel,T=0.30mm	30u"Ni Min.
3	GroundBar	1	Stainless Steel,T=0.15mm	No Plating
2	Contact	16	Copper Alloy,T=0.15mm	Au/Ni-Plated
1	Housing	1	High temperature plastic	UL94 V-0,Black

MANUFACTURE DWG



UNLESS OTHERWISE SPECIFIED TOLERANCES



TITLE:
TYPE-C 16p立式母座H8.8mm

DECIMALS:

.X:±0.35

.XX:±0.25

.XXX:±0.15

ANGLES:

.X':±3.0°

.XX':±2.5°

.XXX':±2.0°

PAR TYPEC-501Y-XCP24H88

DWN

CHKD

APVD

SCALE1:1 UNIT:MM

SIZE:A4 SHEET:1F1

REV:A

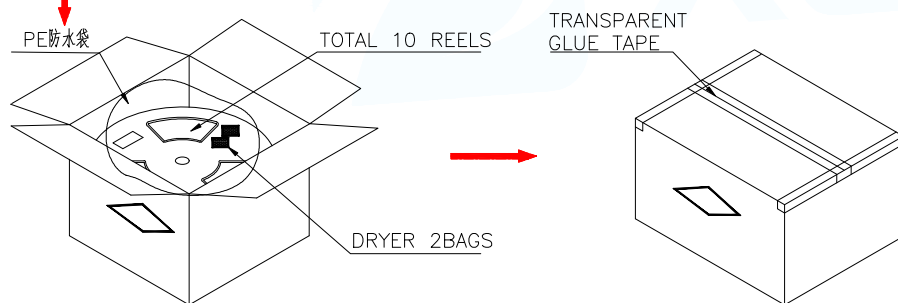
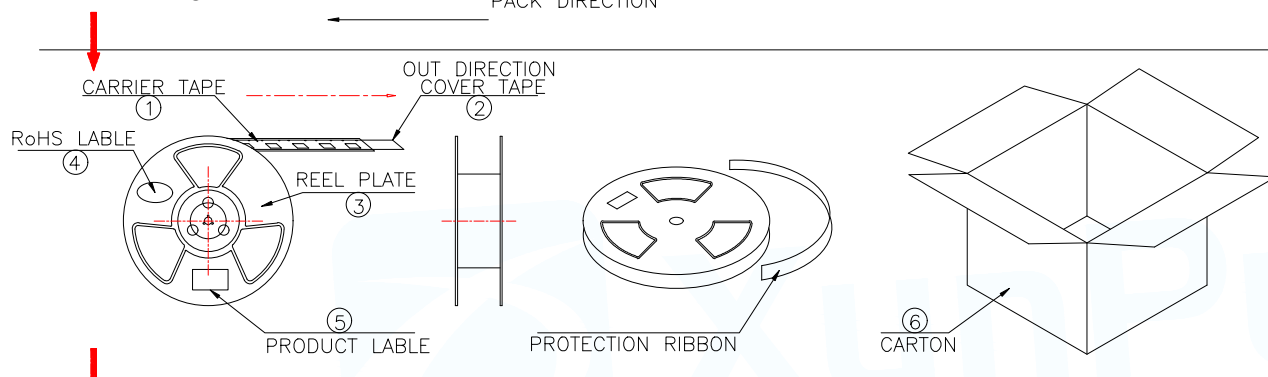
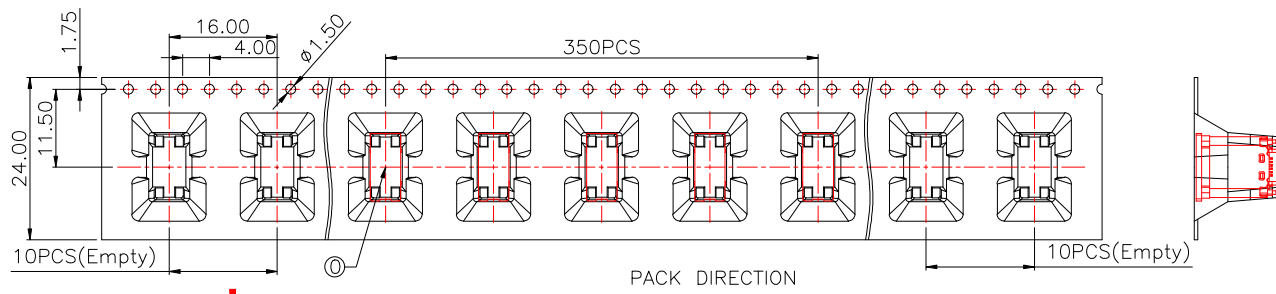

CUSTOMER COPY



说明:

1. 每卷前后各空10PCS,尾部用美纹胶纸封住;
2. 将产品放满盘后,再卷一圈保护带,用美纹胶纸将其封住,并贴上1Pcs物料标签;
3. 每10卷盘一叠共3500Pcs并装入1个外箱内;
4. 在搬运过程中要轻拿轻放;
5. 在运输中不可堆放过多(1.8M最高),不可重压;
6. 跌落测试条件:
成品箱从1.2米高度自由落体(一角三棱六面):
a. 产品不可跑出下带凹槽;
b. 产品不可有摔伤,变形;
c. 内包装材料不可严重破损.

NO.	NAME	SPEC	Q'TY
①	TYPE C RECEPTACLE		3500PCS/CARTON
①	CARRIER TAPE	W=24mm,T=0.50mm	350PCS/PLATE
②	COVER TAPE	W=21.3mm	10PLATES/CARTON
③	REEL PLATE	φ330*100*24.4mm	10PCS/CARTON
④	RoHS LABEL		10PCS/CARTON
⑤	PRODUCT LABER		10PCS/CARTON
⑥	CARTON	350*340*310mm	1PCS/PACKAGE

MANUFACTURE DWG			 东莞市讯普电子科技有限公司 DongGuan XunPu Electronics Co.,Ltd	
UNLESS OTHERWISE SPECIFIED TOLERANCES			TITLE: TYPE-C 16p 贴片式 母座 H8.8mm	
DECIMALS:	ANGLES:	PAR	TYPE-C-501Y-XCP24H88	
.X:±0.35	.X':±3.0°	DWN		
.XX:±0.25	.XX':±2.5°	CHKD		
.XXX:±0.15	.XXX':±2.0°	APVD		
CUSTOMER COPY		SCALE 1:1	UNIT:MM	
		SIZE:A4	SHEET:1F1	REV:A