

SPECIFICATIONS:
 1.MECHANICAL:
 CARD PUSH INSERTION/OUT FORCE:1.0~4.0KG
 DURABILITY: 5000 CYCLES
 2.ELECTRICAL:
 CURRENT RATING: 0.5A
 WITHSTANDING VOLTAGE: 500V AC R.M.S.
 CONTACT RESISTANCE: 100M MAX.
 INSULATION RESISTANCE: 100M MIN.
 3.ENVIRONMENTAL
 TEMPERATURE RANGE -40°C ~ +85°C

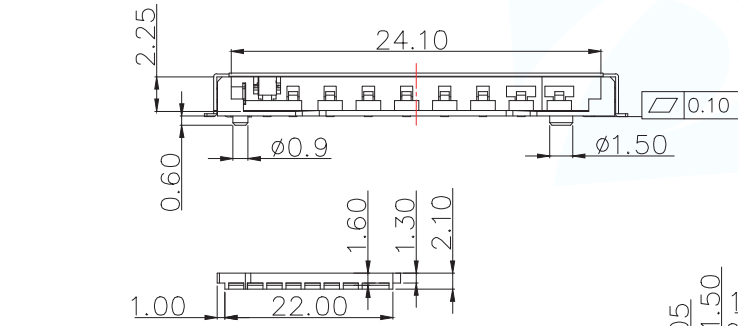

SD CARD PIN DEFINE			
Pin#	Name	Type	Description
1	CD/DAT3	I/O/PP	Card Detect/ Date Line [Bit3]
2	CMD	PP	Command/Response
3	Vss1	S	Supply voltage ground
4	VDD	S	Supply voltage
5	CLK	I	Clock
6	Vss2	S	Supply voltage ground
7	DAT0	I/O/PP	Date Line [Bit0]
8	DAT1	I/O/PP	Date Line [Bit1]
9	DAT2	I/O/PP	Date Line [Bit2]
10	CD		CARD DETECT
11	WP		WRITE PROTECT

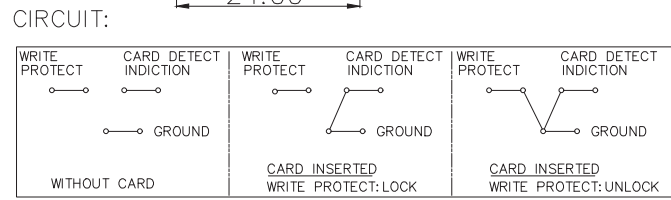
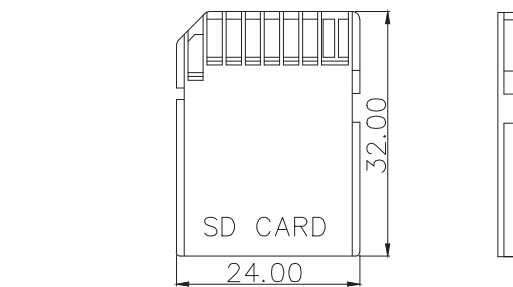
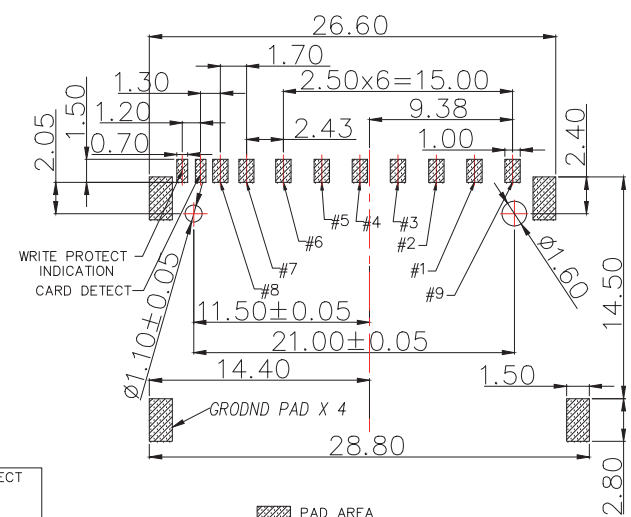
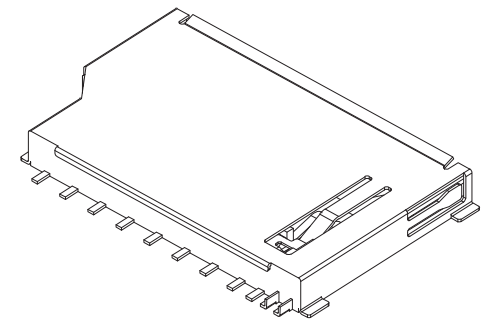

C	SHIELD	1	STAINLESS STEEL 0.20t	Ni PLATING
B	CONTACT	11	COPPER ALLOY 0.20t	Gold Flash On Contact Area Matte-Tin plated on Solder tail All over Nickel Plated .
A	HOUSING	1	THERMOPLASTIC UL94-V0	WHITE
NO	DESCRIPTION	QTY	MATERIAL	PLATING & COLOR
MANUFACTURE DWG		东莞市讯普电子科技有限公司 DongGuan XunPu Electronics Co.,Ltd		
UNLESS OTHERWISE SPECIFIED TOLERANCES		TITLE: SD CARD CONN PUSH SHORT BODY SMT		
DECIMALS:		PAR SD-101-ACP11		
X.: ±0.50		DWN		
X.X: ±0.30		CHKD		
X.XX: ±0.20		APVD		
ANGLES:		SCALE1:1 UNIT: MM		
X.X: ±2°		SIZE: A4 SHEET: 1F1		
X.X: ±1°		REV: A		

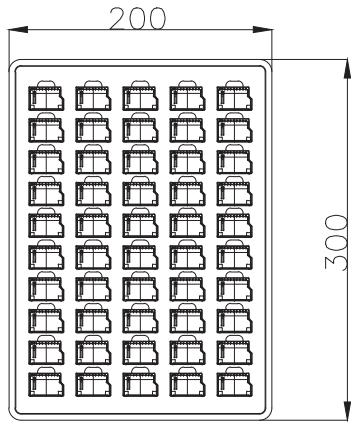

② TRAY
 SPEC: 20.0cm*33.0cm
 QUANTITY: 5X10=50PCS/TRAY

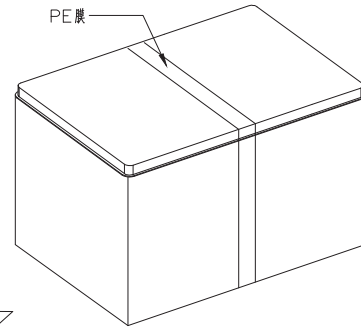

① : CARTON
 SPEC: 40.0cm*31.5cm*23.0cm
 QUANTITY: 50X20X5=5000PCS/CARTON

NOTE :
 Q'TY : 5000PCS/CTN
 N.W. : 6.20 Kg
 G.W. : 9.50 Kg

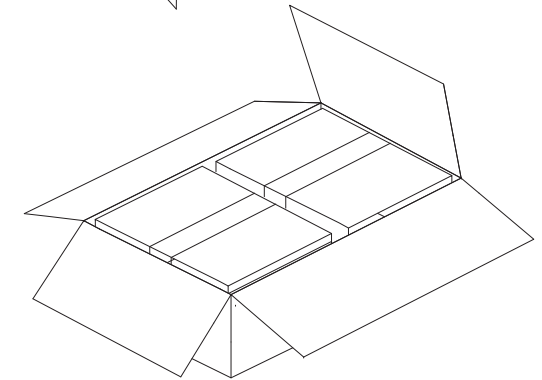
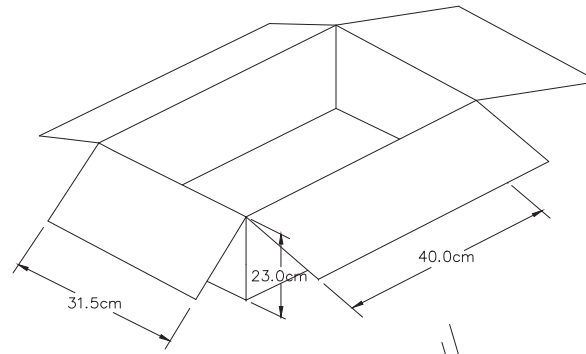
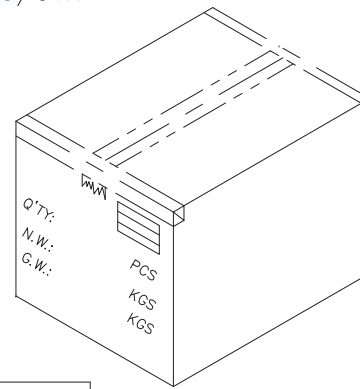

PACKING INFORMATION

PART NAME	SD-101-ACP11
QUANTITY OF PER TRAY	50PCS/TRAY
QUANTITY OF PER CARTON	50*100=5000PCS/CARTON
WEIGHT OF PER CARTON (NET WEIGHT)	6.20Kg
GROSS WEIGHT	9.50Kg
SIZE	40.0cm*31.5cm*23.0cm

② TRAY	PVC	100			
① CARTON	K=K	1			
ITEM	DESCRIPTIONs	MATERIAL	FINISH	Q'TY	NOTE
MANUFACTURE DWG		东莞市讯普电子科技有限公司 DongGuan XunPu Electronics Co.,Ltd			
UNLESS OTHERWISE SPECIFIED TOLERANCES		TITLE: SD CARD CONN PUSH SHORT BODY SMT 封装 PAR SD-101-ACP11 DWN CHKD APVD SCALE:1:1 UNIT: MM SIZE: A4 SHEET: 1F1 REV: A			
DECIMALS:	ANGLES:				
X.: ±0.50	X.: ±2°				
X.X: ±0.30	X.X: ±1°				
X.XX: ±0.20					
CUSTOMER COPY					