

12	13	14	15
MAPX	MODIFICATION	DATE	DRAW

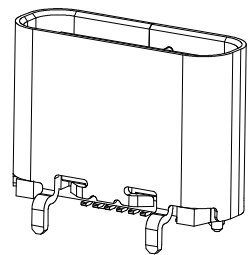

NOTE:

- MATERIAL SPECIFICATION:
 - HOUSING: HIGH TEMPERATURE RESISTANT PLASTIC, UL94 V-0.
 - TERMINAL: COPPER ALLOY (C1815)
 - MID PLATE: STAINLESS STEEL (SUS301)
 - FRONT SHELL: STAINLESS STEEL (SUS304)
- PLATING SPECIFICATION:
 - TERMINAL:
 - Ni 50u" MIN. UNDER PLATED OVER ALL.
 - Au PLATED ON THE FUNCTIONAL AREA OF CONTACT.
 - CONTACT FUNCTIONAL AREA PLATED : Au G/F
 - CONTACT SOLDER AREA PLATED : Au G/F
 - FRONT SHELL:
 - Ni 30u" MIN. UNDER PLATED OVER ALL.
 - MID PLATE:
 - CLEAR ONLY
- MECHANICAL PERFORMANCE,
 - INSERTION FORCE: 0.5~2.0kgf.
 - REMOVAL FORCE: 0.8kgf~2.0kgf.
 - DURABILITY: 10000 CYCLES.
- ELECTRICAL PERFORMANCE,
 - VOLTAGE RATING: 5 V DC/AC (RMS. max)
CURRENT RATING: 5 AMPS. FOR TOTAL VBUS/GND PINS;
1.25AMPS FOR CC PIN, 0.25 AMPS. FOR ALL OTHER CONTACT.
 - LLCR:
 - VBUS & GND PINS AND OTHER PINS: 40mA/PIN MAX.
 - LLCR MAX. CHANGE OF ALL PINS: 10mA.
 - INSULATION RESISTANCE: 100MΩ MIN
 - DIELECTRIC WITHSTAND VOLTAGE, AC 100V FOR 1 MINUTE.
- ENVIRONMENTAL PERFORMANCE:
 - OPERATING TEMPERATURE: -40°C~+85°C.
- IR REFLOW:
 - THE PEAK TEMPERATURE ON THE BOARD SHALL BE MAINTAINED FOR 10 SECONDS AT 260°C.

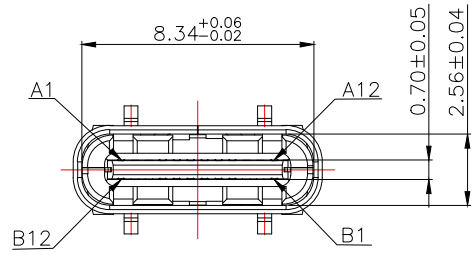
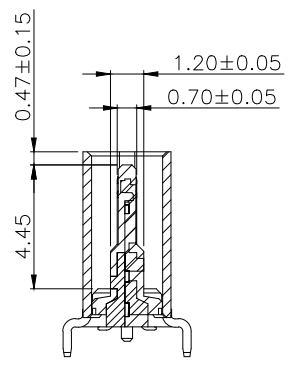
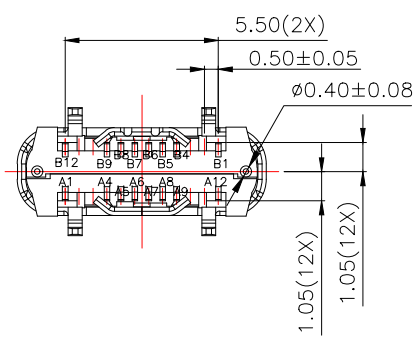
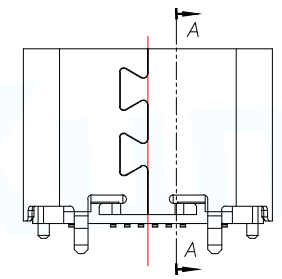
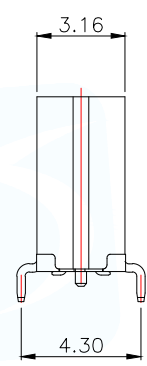
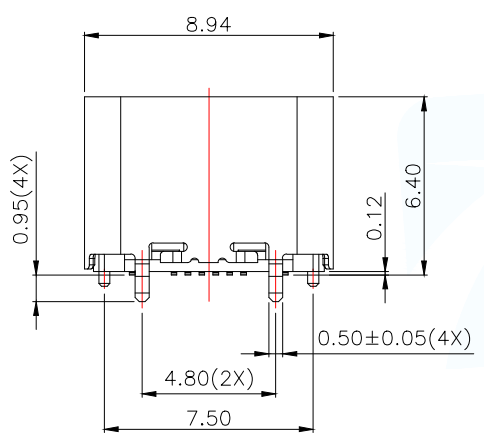

SECTION:A-A

MANUFACTURE DWG		东莞市讯普电子科技有限公司 DongGuan XunPu Electronics Co.,Ltd	
UNLESS OTHERWISE SPECIFIED TOLERANCES			TITLE: USB CF 16PIN VERTICAL W/O EMI SPRING, HIGHT 6.4
DECIMALS:	ANGLES:		PAR TYPEC-303-ECP24
.X: ±0.30	X': ±10°		DWN
.XX: ±0.20	.X': ±8°		CHKD
.XXX: ±0.10	.XX': ±5°	APVD	SCALE 1:1 UNIT: MM
CUSTOMER COPY		SIZE: A4	UNIT: MM
		SHEET: 1F1	REV: A

USB TYPE-C PIN ASSIGNMENTS

PIN NUMBER	SIGNAL NAME	PIN NUMBER	SIGNAL NAME
A1	GND	B12	GND
A4	VBUS	B9	VBUS
A5	CC1	B8	SBU2
A6	Dp1	B7	Dn2
A7	Dn1	B6	Dp2
A8	SBU1	B5	CC2
A9	VBUS	B4	VBUS
A12	GND	B1	GND

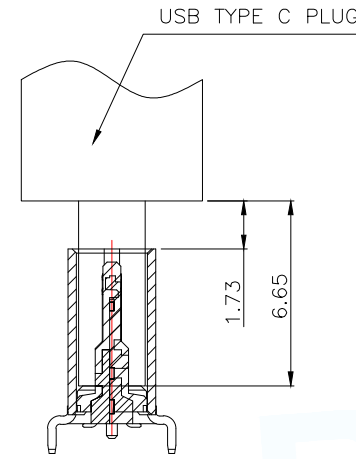

FEMALE AND MALE MATCHING DRAWING

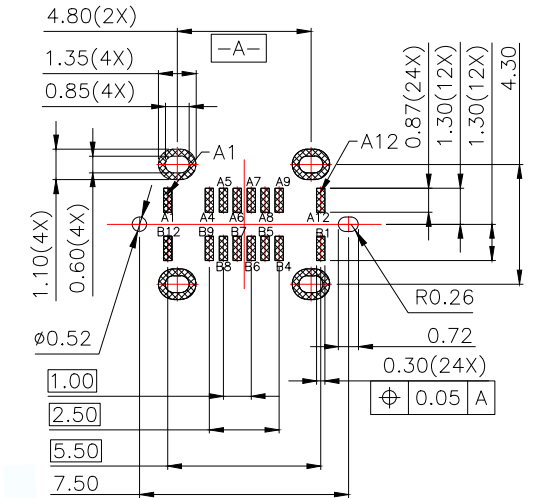

RECOMMENDED PCB LAYOUT(TOP VIEW)
THICKNESS 0.8±0.10MM;DEFAULT TOLERANCE:±0.05

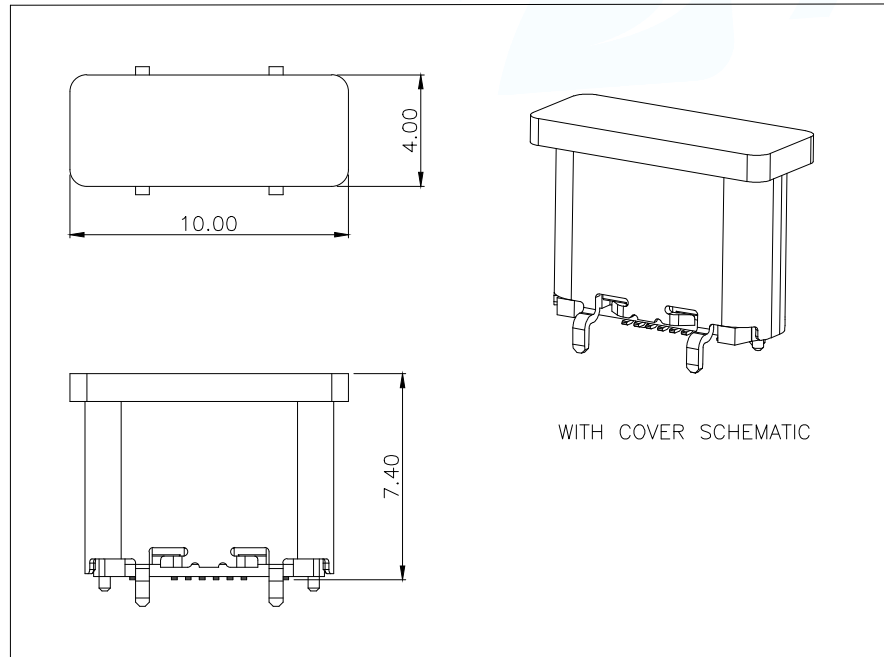

WITH COVER SCHEMATIC

MANUFACTURE DWG		 东莞市讯普电子科技有限公司 DongGuan XunPu Electronics Co.,Ltd	
UNLESS OTHERWISE SPECIFIED TOLERANCES			TITLE: USB CF 16PIN VERTICAL W/O EMI SPRING,HIGHT 6.4
DECIMALS:	ANGLES:		PAR TYPEC-303-ECP24
.X:±0.30	X':±10°		DWN
.XX:±0.20	.X':±8°		CHKD
.XXX:±0.10	.XX':±5°	APVD	SCALE 1:1 UNIT:MM
CUSTOMER COPY		SIZE:A4	SHEET:1F1
			REV:A

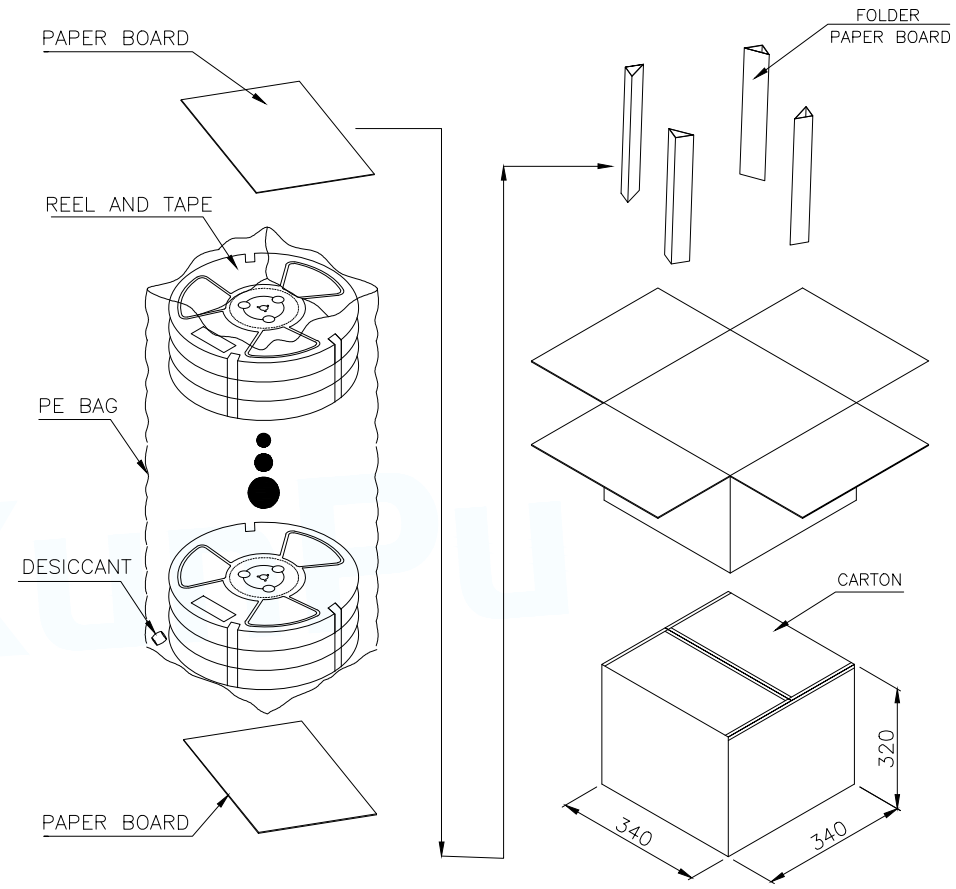
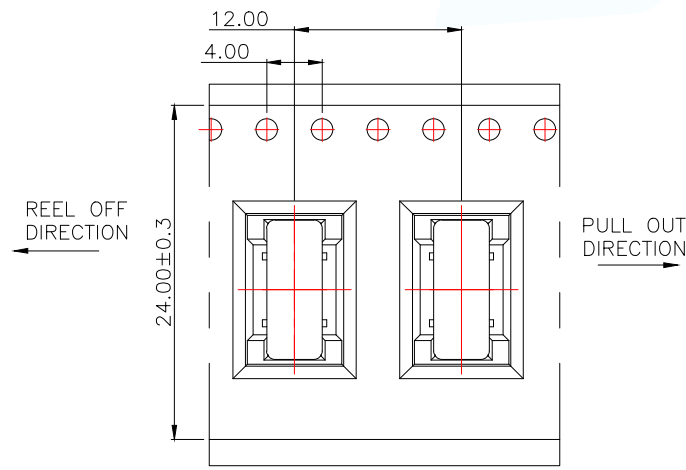
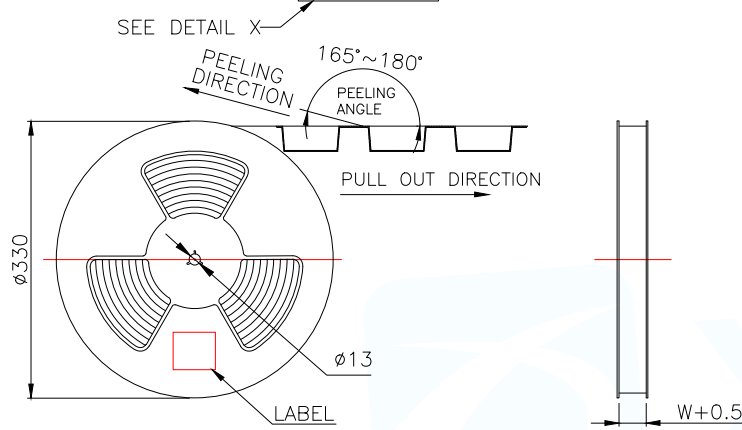
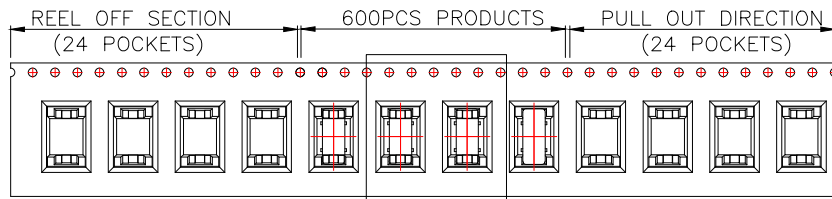

	REEL/TRAY	CARTON
CONNECTOR (PCS)	600	6000

MANUFACTURE DWG		东莞市讯普电子科技有限公司 DongGuan XunPu Electronics Co.,Ltd	
UNLESS OTHERWISE SPECIFIED TOLERANCES		TITLE: USB CF 16PIN VERTICAL W/O EMI SPRING,HIGHT 6.4	
		PAR	TYPEC-303-ECP24
		DWN	
		CHKD	
		APVD	
DECIMALS:	ANGLES:	SCALE 1:1	UNIT:MM
.X:±0.30	X':±10°	SIZE:A4	REV:A
.XX:±0.20	.X':±8°	SHEET:1F1	
.XXX:±0.10	.XX':±5°		



CUSTOMER COPY